



**APEX OPTO
CORP**

HIGH POWER RGB RC STAR Series



RGB RC Series are one of the highest flux LEDs in the world by Apex Opto. It is designed to satisfy applications of Solid-State lighting. It is designed to have three chips in one package. It has various colors for choice and can be independently controlled. More important, it can be pass reflow process.

Features

- Three chips (color) in one package
- Various colors for choice
- Independent control of each color
- More energy efficient than incandescent and most halogen lamps
- Low voltage operated
- Instant light
- Long operating life
- IR reflow process compatible of emitter
- RoHS compliant

Typical Applications

- Up-lighters and Down-lighters
- Contour lights
- Ceiling lights
- Garden lighting
- Architectural lighting
- Beacon lights

Package Outlines

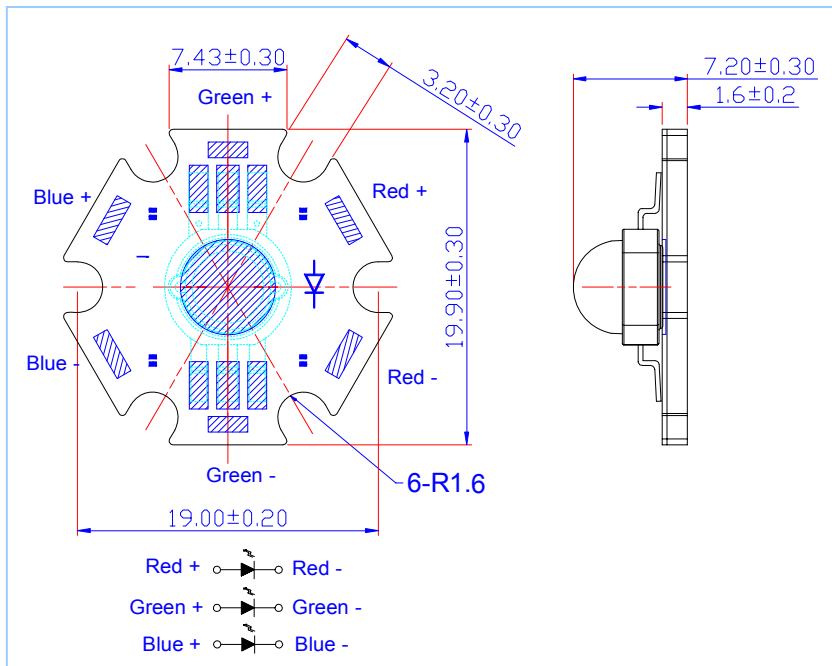

Notes:

1. All dimensions are in mm.
2. Drawings are not to scale.
3. It is strongly recommended that the temperature of lead be not higher than 55°C .

Absolute Maximum Ratings

Parameter	Symbol	Rating	Units
DC Forward Current for each color	I_F	350	mA
Peak pulse current;(tp ≤ 100μs, Duty cycle=0.25)	I_{pulse}	500	mA
Total Wattage	W	3	W
Reverse Voltage	V_R	5	V
Forward Contact Voltage for all colors	V_{FC}	16	V
LED junction Temperature	T_j	150	°C
Operating Temperature	T_{opr}	-30 ~ +130	°C
Storage Temperature	T_{stg}	-40 ~ +150	°C
ESD Sensitivity	V_B	500	V
Manual Soldering Time at 260°C (Max.)	T_{sol}	5	seconds

Notes:

1. Proper current derating must be observed to maintain junction temperature below the maximum.
2. LEDs are not designed to be driven in reserve bias.

Luminous Flux Characteristics at $I_F=350mA(T_j=25°C)$:

Part Name	Color	Flux			Units
		Min.	Typ.	Max.	
AOL-SRTB-1LC6	Red	13.8	22	--	lm
	True Green	30.3	45	--	lm
	Blue	4.8	8	--	lm
AOL-SRTA-1LC6	Red	13.8	22	--	lm
	True Green	30.3	45	--	lm
	Amber	13.8	22	--	lm

Forward Voltage Characteristics at $I_F=350\text{mA}(T_j=25^\circ\text{C})$:

Part Name	Color	V_F			Units
		Min.	Typ.	Max.	
AOL-SRTB-1LC6	Red	--	2.5	--	V
	True Green	--	3.8	--	V
	Blue	--	3.8	--	V
AOL-SRTA-1LC6	Red	--	2.5	--	V
	True Green	--	3.8	--	V
	Amber	--	2.5	--	V

Dominant Wavelength Characteristics at $I_F=350\text{mA}(T_j=25^\circ\text{C})$:

Part Name	Color	λ_d			Units
		Min.	Typ.	Max.	
AOL-SRTB-1LC6	Red	620	--	630	nm
	True Green	515	--	525	nm
	Blue	460	--	470	nm
AOL-SRTA-1LC6	Red	620	--	630	nm
	True Green	515	--	525	nm
	Amber	585	--	595	nm

Temperature coefficient of forward voltage Thermal Resistance Junction to Case at $I_F=350\text{mA}(T_j=25^\circ\text{C})$:

Lens Item	Color	$\Delta V_F/\Delta T$		$R\theta_{J-B}$	
		Typ.	Units	Typ.	Units
AOL-SRTB-1LC6	Red	-2	mV/°C	15	°C/W
	True Green	-2	mV/°C		°C/W
	Blue	-2	mV/°C		°C/W
AOL-SRTA-1LC6	Red	-2	mV/°C	15	°C/W
	True Green	-2	mV/°C		°C/W
	Amber	-2	mV/°C		°C/W

Note

1. Flux is measured with an accuracy of $\pm 10\%$.
2. Forward Voltage is measured with an accuracy of $\pm 0.1\text{V}$
3. Wavelength is measured with an accuracy of $\pm 0.5\text{nm}$
5. All True green and blue emitters are built with InGaN
6. Red、amber emitters are built with AlGaInP

JEDEC Moisture Sensitivity:

Level	Floor Life		Soak Requirements			
	Time	Conditions	Standard		Accelerated Environment	
			Time (hours)	Conditions	Time (hours)	Conditions
2a	4 weeks	≤ 30°C / 60% RH	696 +5/-0	30°C / 60% RH	120 +1/-0	60°C / 60% RH

LEVEL	FLOOR LIFE		SOAK REQUIREMENTS			
			STANDARD		ACCELERATED EQUIVALENT ¹	
	TIME	CONDITIONS	TIME (hours)	CONDITIONS	TIME (hours)	CONDITIONS
1	Unlimited	≤30°C/85% RH	168 +5/-0	85°C/85% RH		
2	1 year	≤30°C/80% RH	168 +5/-0	85°C/80% RH		
2a	4 weeks	≤30°C/80% RH	696 ² +5/-0	30°C/80% RH	120 +1/-0	60°C/80% RH
3	168 hours	≤30°C/80% RH	192 ² +5/-0	30°C/80% RH	40 +1/-0	60°C/80% RH
4	72 hours	≤30°C/80% RH	96 ² +2/-0	30°C/80% RH	20 +0.5/-0	60°C/80% RH
5	48 hours	≤30°C/80% RH	72 ² +2/-0	30°C/80% RH	15 +0.5/-0	60°C/80% RH
5a	24 hours	≤30°C/80% RH	48 ² +2/-0	30°C/80% RH	10 +0.5/-0	60°C/80% RH
6	Time on Label (TOL)	≤30°C/80% RH	TOL	30°C/80% RH		

Note

1. The standard soak time includes a default value of 24 hours for semiconductor manufacturer's exposure time (MET) between bake and bag and includes the maximum time allowed out of the bag at the distributor's facility.

Operating life, mechanical, and environmental tests performed on APEX package:

Stress Test	Stress Conditions	Stress Duration	Failure Criteria
Room Temperature Operating Life	25°C, I _F = max DC (Note 1)	1000 hours	Note 2
High Temperature High Humidity	85°C / 85%RH	1000 hours	Note 2
Temperature Cycle	-40°C/100°C ,30 min dwell / < 5min transfer	200 cycles	Note 2
High Temperature Storage Life	110°C	1000 hours	Note 2
Low Temperature Storage Life	-55°C	1000 hours	Note 2
Thermal Shock	-40 / 120°C, 20 min dwell / < 20 sec transfer	200 cycles	No catastrophics
Mechanical Shock	1500 G, 0.5 msec pulse, 5 shocks each 6		No catastrophics
Natural Drop	On concrete from 1.2 m, 3X		No catastrophics
Variable Vibration Frequency	10-2000-10 Hz, log or linear sweep rate, 20 G about 1 min, 1.5 mm, 3X/axis		No catastrophics
Solder Heat Resistance (SHR)	260°C ± 5°C, 10 sec		No catastrophics
Solderability	Steam age for 16 hr, then solder dip at 260°C for 5 sec		Solder coverage on lead

Note

1. Depending on the maximum derating curve.
2. Failure Criteria:

Electrical failures

V_F shift >=10%

I_R<50uA @V_r=5V

Light Output Degradation

% I_v shift >= 30% @1000hrs or 200cycle

Visual failures

Broken or damaged package or lead

Solderability < 95% wetting

Dimension out of tolerance

Burn-in Condition RC Series Reliability(I_F=350mA)

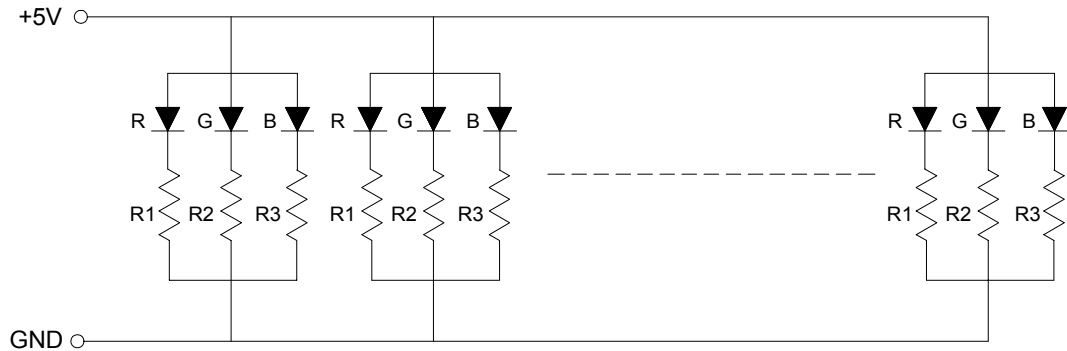

When we talk about MTBF of APEX, we can provide a formula for customers.

$$\log(\text{Life}) = \frac{1600}{T_j(^{\circ}\text{C}) + 273}$$

Life means the time light output becomes 70%

T _j (°C)	Life (hours)	T _j (°C)	Life (hours)
25	234,000	85	29,500
30	191,000	90	25,700
35	157,000	95	22,300
40	129,000	100	19,500
45	107,000	105	17,100
50	90,000	110	15,100
55	75,000	115	13,300
60	64,000	120	11,700
65	54,000	125	10,500
70	46,000	130	9,300
75	39,600	140	7,500
80	34,000	150	6,000

When we talk about MTBF of APEX, we can provide a formula for customers

MTBF is assumed to be 100,000,000

The failure rates at different hours and different systems(LED quantity) are as below:

if there is 1 failure of 1 emitter in a system

Tj=75°C is giving 0.01%(100ppm) at 10,000hrs

if there is 1 failure of 10 emitters in a system

Tj=75°C is giving 0.1%(1,000ppm) at 10,000hrs

if there is 1 failure of 1 emitter in a system

Tj=75°C is giving 0.05%(500ppm) at 50,000hrs

if there is 1 failure of 10 emitters in a system

Tj=75°C is giving 0.5%(5,000ppm) at 50,000hrs if there are 10 emitters

How to Know Tj in Your Application?

If it is APEX, Rth(junction to case)=15°C/W

The thermal grease is 200um.

K(Aluminum PCB)=2.6 W/mk

Then Rth(case-board)= $\frac{200}{2.6 \times (6.4/2)^2 \pi} = 2.4$

The Rth between board and air is mainly dependent on the total surface air.

Rth(board-air) = $\frac{500}{\text{Area}(\text{cm}^2)}$

If Area is 30cm² Rth=16.7 there for Rth(junction-air)=(15+2.4+16.7)x3=92.3 °C/3W

If Area is 60cm² Rth=8.3 there for Rth(junction-air)=(15+2.4+8.3)x3=67.1 °C/3W

If Area is 90cm² Rth=5.5 there for Rth(junction-air)=(15+2.4+5.5)x3=58.7 °C/3W

ASSIST FORM about High Power LED Reliability.(Ex:Blue color)

	Ts=45°C	Ts=65°C	Ts=85°C
Voltage	3.8V	3.8V	3.8V
Current	350mA	350mA	350mA
Wattage	1.3W	1.3W	1.3W
Heat	1.1W	1.1W	1.1W
Rth	15 °C/W	15 °C/W	15 °C/W
Tj	61.5 °C	81.5 °C	101.5°C
L70%	62,000hrs	33,000hrs	20,000hrs

Spectrum

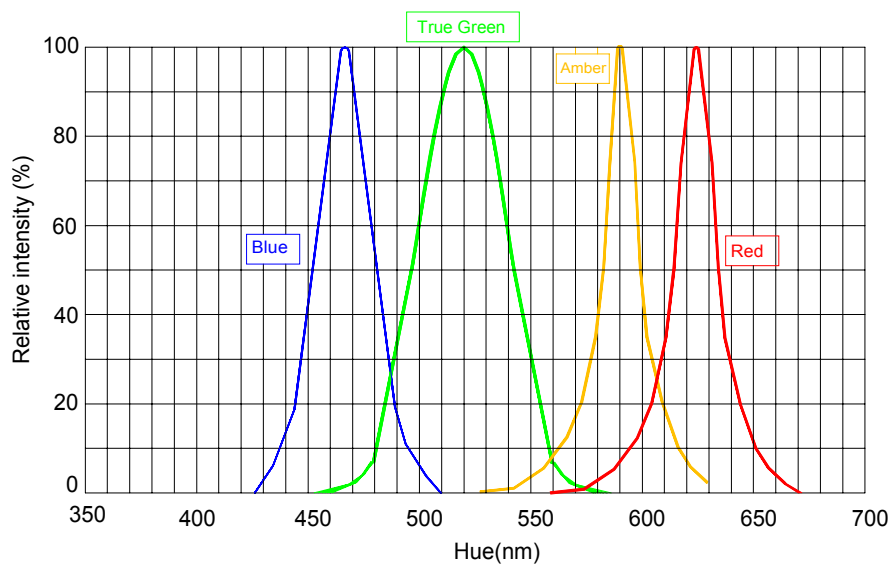

Junction temperature & Relative Flux

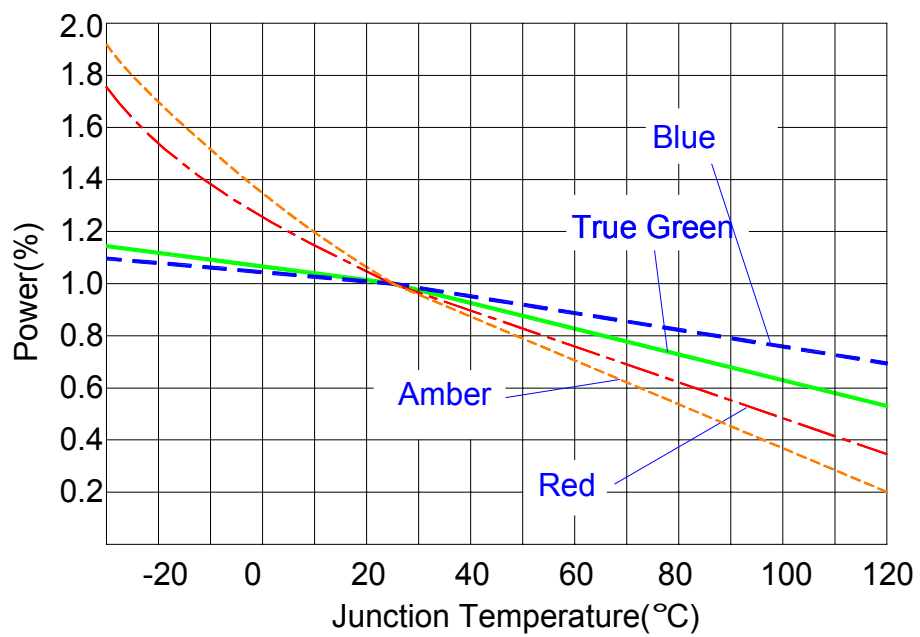

Typical Radiation Pattern for Lambertian

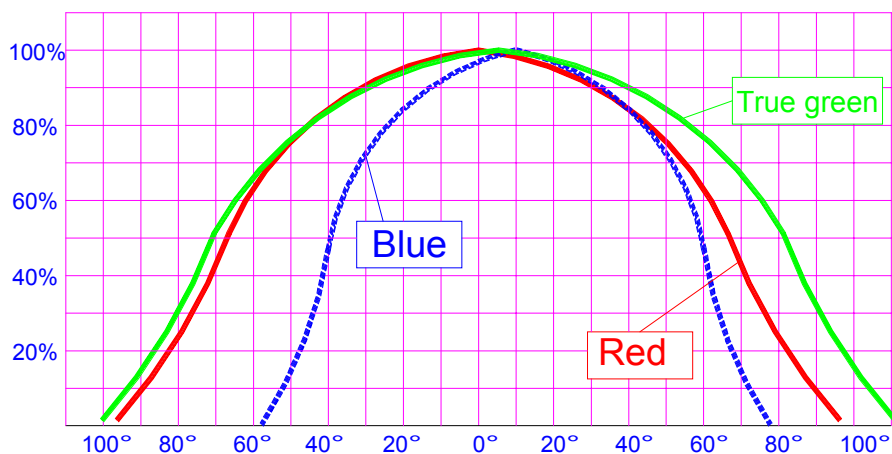

Typical Optical and Electrical Curves

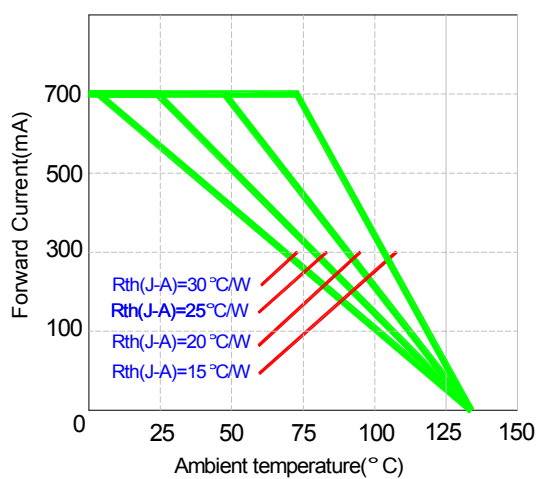

Operating Current & Ambient Temperature

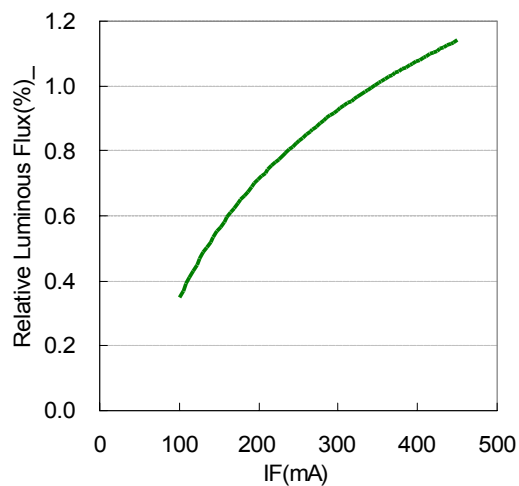

Forward Current & Luminous Flux

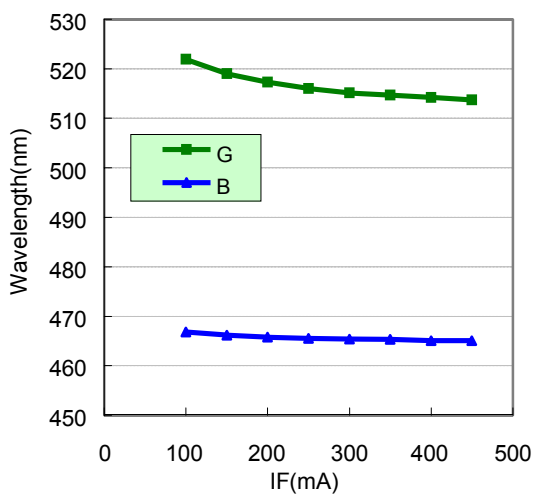

Forward Current & Wavelength

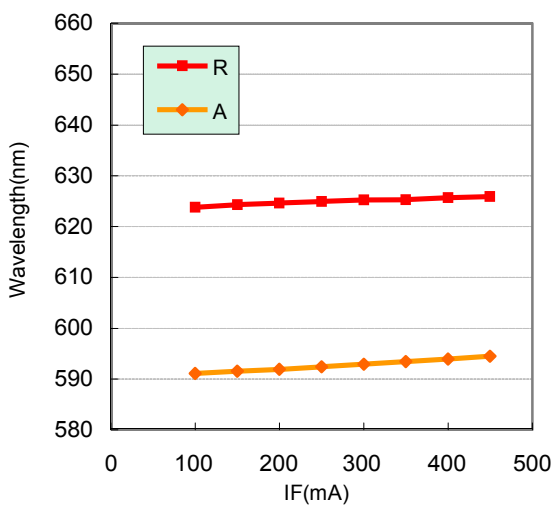

Package Specifications

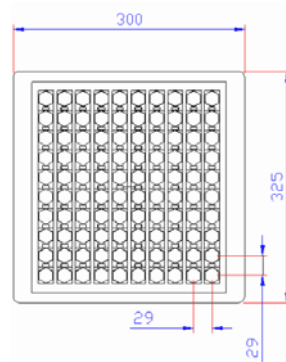
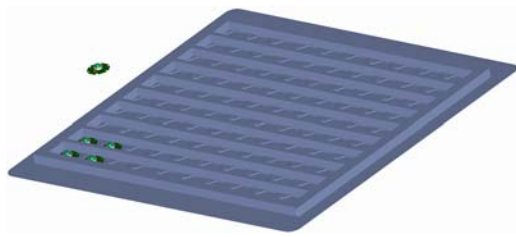

Figure 1: Tray

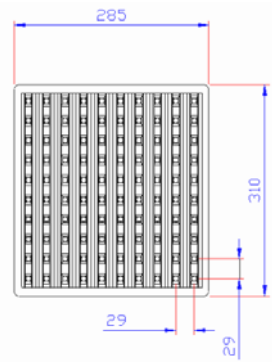

Figure 2: Cover

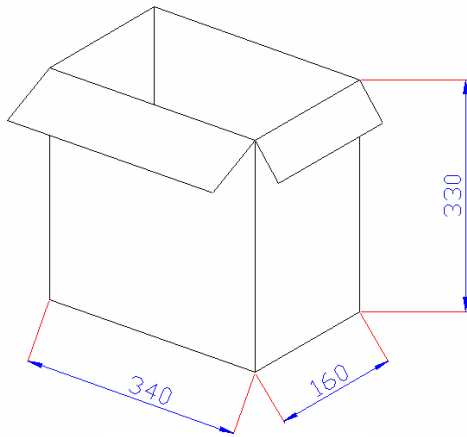

Figure 3: Inner box

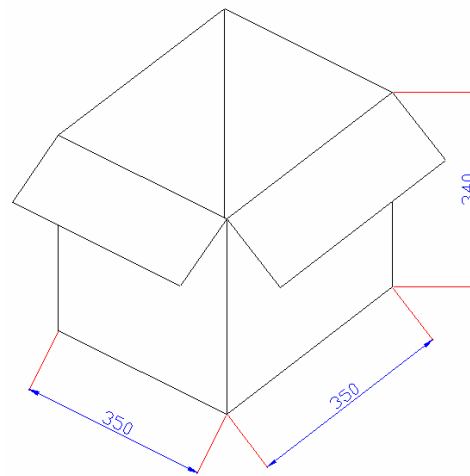

Figure 4: Outer box

Notes

1. Inner antistatic bag standard.
2. 50pcs emitters per tray (Carrier + Cover)
3. 10 trays per bag and an inner box, 1K pcs per inner box.
4. 2 inner boxes per outer box, 2 K pcs per outer box.

Packing Step	Type	Dimension(mm)	Star Q'ty(Max.)
1	Tray	325*300	100
2	Inner Box	340*160*330	1,000
3	Outer Box	350*350*340	2,000