



**APEX OPTO
CORP**

**POWER UV LIGHT
AOL-UVXLA1**



Ultraviolet Series are one of the highest power LEDs in the world by Apex Opto Corp. Ultraviolet APEX are designed for ultraviolet curing.

Features

- Low voltage operated
- Long operating life

Typical Applications

- Ultraviolet curing

Package Outlines

Lambertian

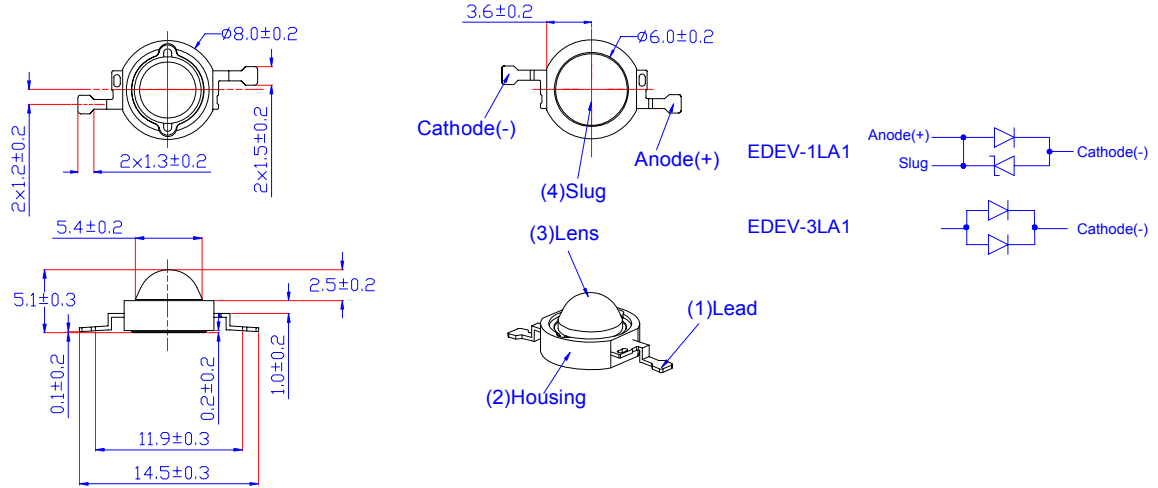

Notes:

1. All dimensions are in mm.
2. Drawings are not to scale.
3. It is strongly recommended that the temperature of lead be not higher than 55°C.
4. It is important that the slug can't contact aluminum surface, It is strongly recommended that there should coat a uniform electrically isolated heat dissipation film on the aluminum surface.

Absolute Maximum Ratings

Parameter	Symbol	Rating	Units
DC Forward Current for 1W	I_F	350	mA
DC Forward Current for 3W	I_F	700	mA
1W emitter Peak pulse current;(tp ≤ 100μs, Duty cycle=0.25)	I_{pulse}	1000	mA
3W emitter Peak pulse current;(tp ≤ 100μs, Duty cycle=0.25)	I_{pulse}	1500	mA
Reverse Voltage	V_R	5	V
LED junction Temperature	T_j	125	°C
Operating Temperature	T_{opr}	-30 ~ +110	°C
Storage Temperature	T_{stg}	-40 ~ +120	°C
ESD Sensitivity	V_B	500	V
Manual Soldering Time at 260°C (Max.)	T_{sol}	5	seconds

Electric and Optical Characteristics 1W at $I_F=350mA$ & 3W at $I_F=700mA$ ($T_i=25°C$):

Part No.	Item	Symbol	Value			Units
			Min.	Typ.	Max.	
AOL-UV1LA1	Radiometric Power	Φ_V	113.9	180	--	mW
AOL-UV3LA1			256.3	350	--	mW
AOL-UV1LA1	Peak Wavelength	λ_P	395	--	410	nm
AOL-UV3LA1			395	--	410	nm
AOL-UV1LA1	Forward Voltage	V_F	2.8	3.5	4.0	V
AOL-UV3LA1			2.8	3.5	4.0	V
AOL-UV1LA1	Emission Angle	$2\theta_{1/2}$	--	140	--	Degree
AOL-UV3LA1			--	140	--	Degree
AOL-UV1LA1	Thermal Resistance	$R_{\theta_{J-B}}$	--	20	--	°C/W
AOL-UV3LA1			--	10	--	°C/W

Note

1. Radiometric power is measured with an accuracy of ± 10%.
2. Forward Voltage is measured with an accuracy of ± 0.1V
3. Wavelength is measured with an accuracy of ± 0.5nm
4. All emitters are built with InGaN

JEDEC Moisture Sensitivity:**Soak Requirements**

Level	Floor Life		Standard		Accelerated Environment	
	Time	Conditions	Time (hours)	Conditions	Time (hours)	Conditions
4	72hours	$\leq 30^{\circ}\text{C}$ /60% RH	96 +2/-0	30°C / 60% RH	20 +0.5/-0	60°C / 60% RH

Operating life, mechanical, and environmental tests performed on APEX package:

Stress Test	Stress Conditions	Stress Duration	Failure Criteria
Room Temperature Operating Life	25°C, $I_F = \text{max DC}$ (Note 1)	1000 hours	Note 2
High Temperature High Humidity	85°C / 85%RH	1000 hours	Note 2
Temperature Cycle	-40°C/100°C ,30 min dwell / <5min transfer	200 cycles	Note 2
High Temperature Storage Life	110°C	1000 hours	Note 2
Low Temperature Storage Life	-55°C	1000 hours	Note 2
Thermal Shock	-40 / 120°C, 20 min dwell / <20 sec transfer	200 cycles	No catastrophics
Mechanical Shock	1500 G, 0.5 msec pulse, 5 shocks each 6 axis		No catastrophics
Natural Drop	On concrete from 1.2 m, 3X		No catastrophics
Variable Vibration Frequency	10-2000-10 Hz, log or linear sweep rate, 20 G about 1 min, 1.5 mm, 3X/axis		No catastrophics
Solder Heat Resistance (SHR)	260°C $\pm 5^{\circ}\text{C}$, 10 sec		No catastrophics
Solderability	Steam age for 16 hr, then solder dip at 260°C for 5 sec		Solder coverage on lead

Notes:

1. Depending on the maximum derating curve.

2. Failure Criteria:

Electrical failures

V_F shift $\geq 10\%$

$I_R < 50\mu\text{A}$ @ $V_r = 5\text{V}$

Light Output Degradation

% I_v shift $\geq 30\%$ @1,000hrs or 200cycle

Visual failures

Broken or damaged package or lead

Solderability < 95% wetting

Dimension out of tolerance

Burn-in Condition APEX Reliability

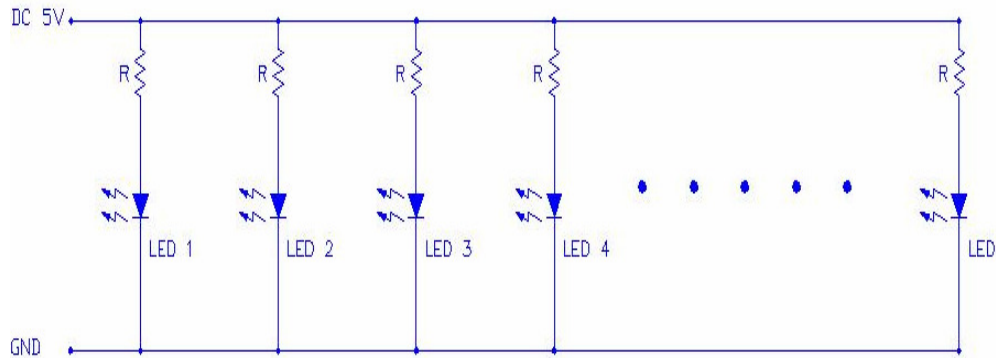

When we talk about MTBF of APEX, we can provide a formula for customers.

$$\log(\text{Life}) = \frac{1.600}{T_j(^{\circ}\text{C}) + 273}$$

Life means the time light output becomes 70%.

T _j (°C)	Life (hours)	T _j (°C)	Life (hours)
25	234,000	85	29,500
30	191,000	90	25,700
35	157,000	95	22,300
40	129,000	100	19,500
45	107,000	105	17,100
50	90,000	110	15,100
55	75,000	115	13,300
60	64,000	120	11,700
65	54,000	125	10,500
70	46,000	130	9,300
75	39,600	140	7,500
80	34,000	150	6,000

When we talk about MTBF of APEX, we can provide a formula for customers

MTBF is assumed to be 100,000,000

The failure rates at different hours and different systems(LED quantity) are as below:

if there is 1 failure of 1 emitter in a system

$T_j=75^{\circ}\text{C}$ is giving 0.01%(100ppm) at 10,000hrs if there is 1

failure of 10 emitters in a system

$T_j=75^{\circ}\text{C}$ is giving 0.1%(1,000ppm) at 10,000hrs

if there is 1 failure of 1 emitter in a system

$T_j=75^{\circ}\text{C}$ is giving 0.05%(500ppm) at 50,000hrs if there is 1

failure of 10 emitters in a system

$T_j=75^{\circ}\text{C}$ is giving 0.5%(5,000ppm) at 50,000hrs if there are 10 emitters

How to Know T_j in Your Application?

If it is 1W APEX, $R_{th}(\text{junction to case})=15^{\circ}\text{C/W}$

The thermal grease is 200um.

$K(\text{Aluminum PCB})=2.6 \text{ W/mk}$

Then $R_{th}(\text{case to board})=\frac{200}{2.6 \times (6.4/2)^2 \pi}=2.4^{\circ}\text{C/W}$

The R_{th} between board and air is mainly dependent on the total surface air.

$R_{th}(\text{board-air}) \approx \frac{500}{\text{Area}(\text{cm}^2)}$

If Area is 30cm^2 $R_{th}=16.7$ $\Delta T(\text{junction-air})=(15+2.4+16.7) \times 1=34.1^{\circ}\text{C}$

If Area is 60cm^2 $R_{th}=8.3$ $\Delta T(\text{junction-air})=(15+2.4+8.3) \times 1=25.7^{\circ}\text{C}$

If Area is 90cm^2 $R_{th}=5.5$ $\Delta T(\text{junction-air})=(15+2.4+5.5) \times 1=22.9^{\circ}\text{C}$

ASSIST FORM about High Power LED Reliability(1W APEX)

	<u>$T_s=45^{\circ}\text{C}$</u>	<u>$T_s=65^{\circ}\text{C}$</u>	<u>$T_s=85^{\circ}\text{C}$</u>
Voltage	3.5V	3.5V	3.5V
Current	350mA	350mA	350mA
Wattage	1.2W	1.2W	1.2W
Heat	1.0W	1.0W	1.0W
Rth	15°C/W	15°C/W	15°C/W
T_j	60°C	80°C	100°C
$L_{70\%}$	64,000hrs	34,000hrs	19,500hrs

Typical Radiation Pattern

Lambertian

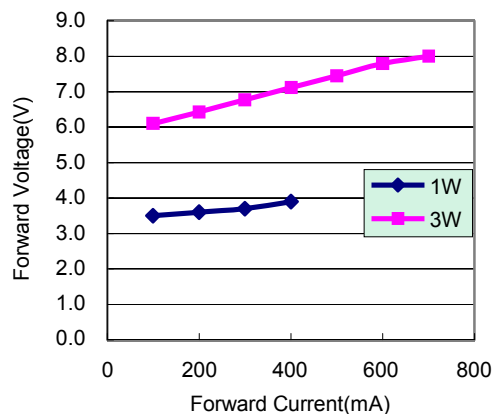
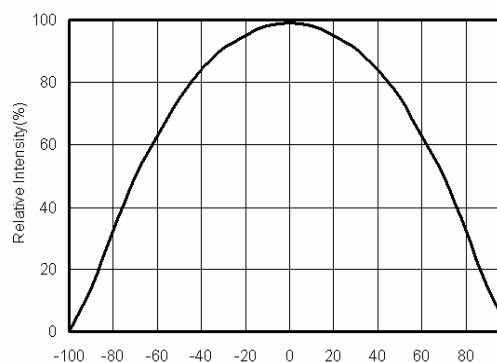

Typical Optical and Electrical Curves

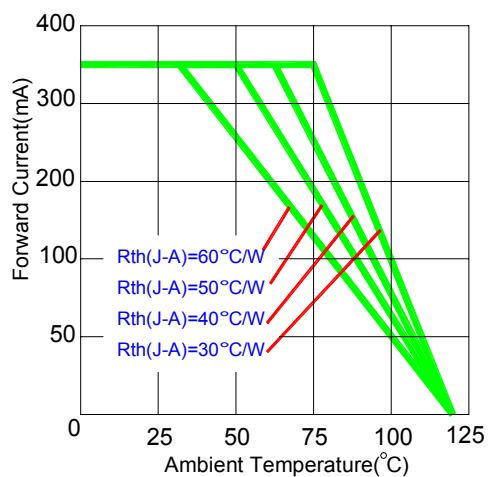

Operating Current & Ambient Temperature
For 1W emitter

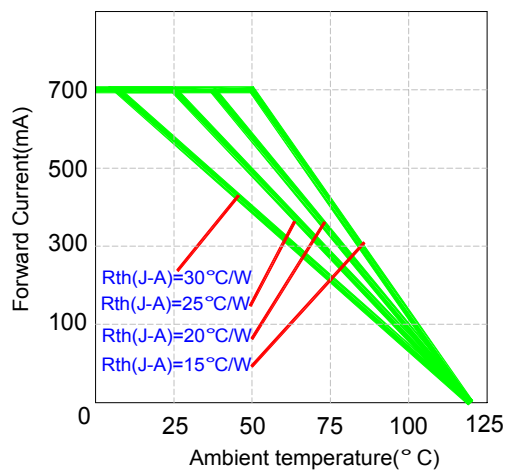

Forward Current & Luminous Flux
For 3W emitter

Adhesive for Emitter to Aluminum PCB

Suggestion:

- **Ease of use**
Non-solvent, One-part
- **Fast tack free**
3 minutes at 25°C
- **No corrosion**
Alcohol type of RTV
- **Low volatility**
Low weight loss of silicone volatiles
- **Adhesion**
Excellent adhesion to most materials without use of a primer
- **Dielectric properties**
Cured rubber exhibits good dielectric properties
- **Excellent thermal stability and cold resistance**
Cured rubber provides wide service temperature range

Typical Properties

Specification	Suggested Properties
Take-free time	3~10 minutes
Specific gravity	< 3 g/cm ²
Thermal conductivity	> 2.5 W/mK
Rth in using	< 1.8 °C/W
Volume resistance	> 1x10 ¹⁴
Lap shear adhesion strength	> 200 N/ cm ²
Tensile strength	> 4 Mpa

Thrust for APEX Lens

Lens Type	Typical Thrust
Lambertian Lens	5 kgf

Package Specifications

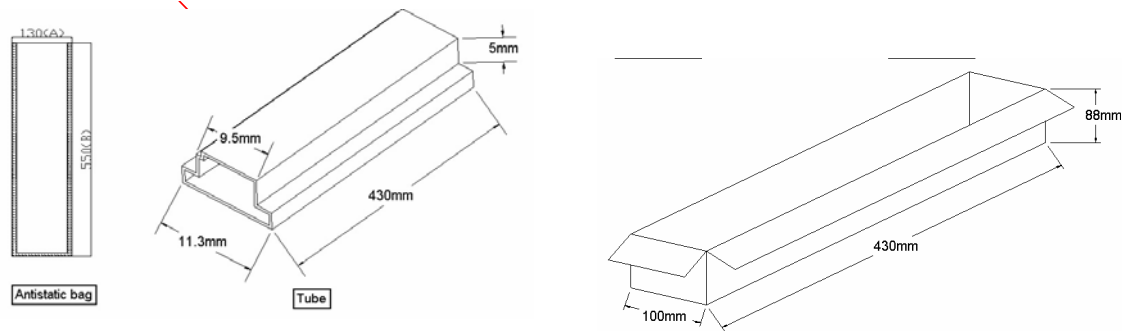

Note

1. Inner antistatic bag standard.
2. A bag contains one humidity indicator card and drying agent.
3. 50pcs emitters per tube.
4. 20 tubes per bag, 1 K pcs per bag.
5. 2 bags per inner box, 2 K pcs per inner box.

Packing Step	Type	Dimension(mm)	Emitter Q'ty(Max.)
1	Tube	430*13	50
2	Inner Box	430*100*88	1,000
3	Outer Box	460*196*135	2,000