



**APEX OPTO  
CORP**

## **HIGH POWER LIGHT AOL-SX3LAX 3W STAR Series**



APEX are designed by particular package for High Power LED.

3W APEX white has more than 90 lumens @700mA. Unlike most fluorescent sources, APEX contains no mercury and has more energy efficient than other incandescent light source.

### **Features**

- Various colors
- More energy efficient than incandescent and most halogen lamps
- Low voltage operated
- Instant light
- Long operating life

### **Typical Applications**

- Reading lights
- Portable flashlight
- Up-lighters and Down-lighters
- LCD Backlights
- General lighting
- Contour lights
- Ceiling lights
- Garden lighting
- Decoration lights
- Architectural lighting
- Beacon lights

## **Package Outlines**

### **Lambertian**

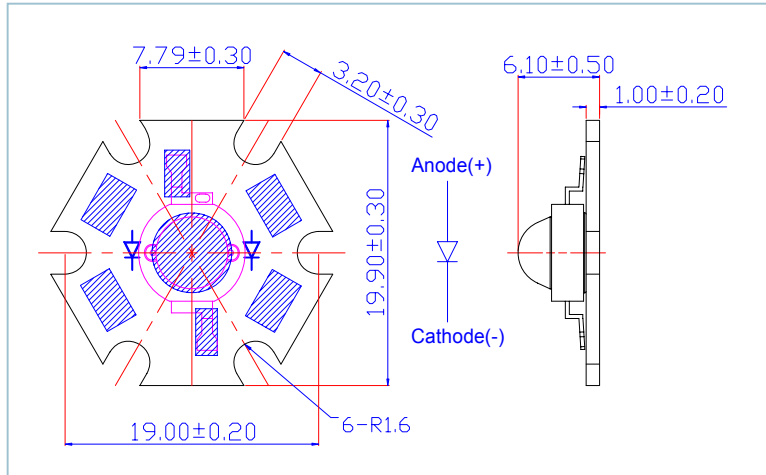

### **Notes:**

1. All dimensions are in mm.
2. It is strongly recommended that the temperature of lead be not higher than  $55^{\circ}\text{C}$

### Absolute Maximum Ratings

Parameter	Symbol	Rating	Units
DC Forward Current	$I_F$	700	mA
Peak pulse current;(tp ≤ 100μs, Duty cycle=0.25)	$I_{pulse}$	1000	mA
Reverse Voltage	$V_R$	5	V
Reverse Current( $V_R=5V$ )	$I_R$	50	μA
LED junction Temperature ( at 350 mA)	$T_j$	125	°C
Operating Temperature	$T_{opr}$	-30 ~ +110	°C
Storage Temperature	$T_{stg}$	-40 ~ +120	°C
Manual Soldering Time at 260°C (Max.)	$T_{sol}$	5	seconds

### Luminous Flux Characteristics at $I_F=700mA(T_a=25°C, T_{opr}=100ms)$ :

Lens Item	Part Name	Color	Flux			Units
			Min.	Typ.	Max.	
Lambertian	AOL-SW3Lax	White	51.2	90	--	lm
	AOL-SX3Lax	Warm White	39.4	60	--	lm
	AOL-SR3Lax	Red	39.4	65	--	lm
	AOL-SO3Lax	Red Orange	51.2	70	--	lm
	AOL-SA3Lax	Amber	39.4	65	--	lm
	AOL-ST3Lax	True Green	51.2	90	--	lm
	AOL-SB3Lax	Blue	13.8	30	--	lm

### Luminous Flux Characteristics at $I_F=1000mA$ or $1400mA(T_a=25°C, T_{opr}=100ms)$ :

Lens Item	Part Name	Color	Flux(Typ.)		Units
			1000mA	1400mA	
Lambertian	AOL-SW3Lax	White	120.0	--	lm
	AOL-SX3Lax	Warm White	80.0	--	lm
	AOL-SR3Lax	Red	--	110.0	lm
	AOL-SO3Lax	Red Orange	--	120.0	lm
	AOL-SA3Lax	Amber	--	100.0	lm
	AOL-ST3Lax	True Green	120.0	--	lm
	AOL-SB3Lax	Blue	90.0	--	lm

**Forward Voltage Characteristics at  $I_F=700\text{mA}$  ( $T_a=25^\circ\text{C}$ ,  $T_{opr}=100\text{ms}$ ):**

Lens Item	Part Name	Color	$V_F$			Units
			Min.	Typ.	Max.	
	AOL-SW3Lax	White	3.1	--	4.3	V
	AOL-SX3Lax	Warm White	3.1	--	4.3	V
	AOL-SR3Lax	Red	2.0	--	3.0	V
Lambertian	AOL-SO3Lax	Red Orange	2.0	--	3.0	V
	AOL-SA3Lax	Amber	2.0	--	3.0	V
	AOL-ST3Lax	True Green	2.8	--	4.0	V
	AOL-SB3Lax	Blue	3.1	--	4.3	V

**Wavelength or Color Temperature Characteristics at  $I_F=700\text{mA}$  ( $T_a=25^\circ\text{C}$ ,  $T_{opr}=100\text{ms}$ ):**

Lens Item	Part Name	Color	$\lambda_d/\text{CCT}$			Units
			Min.	Typ.	Max.	
	AOL-SW3Lax	White	5000	--	8000	K
	AOL-SX3Lax	Warm White	2800	--	3800	K
	AOL-SR3Lax	Red	620	--	630	nm
Lambertian	AOL-SO3Lax	Red Orange	610	--	620	nm
	AOL-SA3Lax	Amber	585	--	595	nm
	AOL-ST3Lax	True Green	515	--	535	nm
	AOL-SB3Lax	Blue	460	--	475	nm

**Temperature Coefficient of Forward Voltage & Thermal Resistance Junction to Board Characteristics at  $I_F=700\text{mA}$  ( $T_a=25^\circ\text{C}$ ):**

Lens Item	Part Name	Color	$\Delta V_F/\Delta T$		$R\theta_{J-B}$	
			Typ.	Units	Typ.	Units
	AOL-SW3Lax	White	-2	mV/°C	20	°C/W
	AOL-SX3Lax	Warm White	-2	mV/°C	20	°C/W
	AOL-SR3Lax	Red	-2	mV/°C	20	°C/W
Lambertian	AOL-SO3Lax	Red Orange	-2	mV/°C	20	°C/W
	AOL-SA3Lax	Amber	-2	mV/°C	20	°C/W
	AOL-ST3Lax	True Green	-2	mV/°C	20	°C/W
	AOL-SB3Lax	Blue	-2	mV/°C	20	°C/W

**Emission Angle Characteristics at  $I_F=700\text{mA}$  ( $T_a=25^\circ\text{C}$ ):**

Part Name	Color	$2\theta^{1/2}$			Units
		Max.	Typ.	Min.	
AOL-SW3Lax	White	--	130	--	Degrees
AOL-SX3Lax	Warm White	--	130	--	Degrees
AOL-SR3Lax	Red	--	120	--	Degrees
AOL-SO3Lax	Red Orange	--	120	--	Degrees
AOL-SA3Lax	Amber	--	120	--	Degrees
AOL-ST3Lax	True Green	--	150	--	Degrees
AOL-SB3Lax	Blue	--	150	--	Degrees

**Note**

1. Flux is measured with an accuracy of  $\pm 10\%$ .
2. CCT selection acc. to CCT groups and an accuracy of  $\pm 200\text{K}$
3. Forward Voltage is measured with an accuracy of  $\pm 0.1\text{V}$
4. Wavelength is measured with an accuracy of  $\pm 0.5\text{nm}$
5. All white, warm white and blue emitters are built with InGaN
6. All red, red-orange and amber emitters are built with AlGaInP

## Electrical & Optical Curves-Spectrum

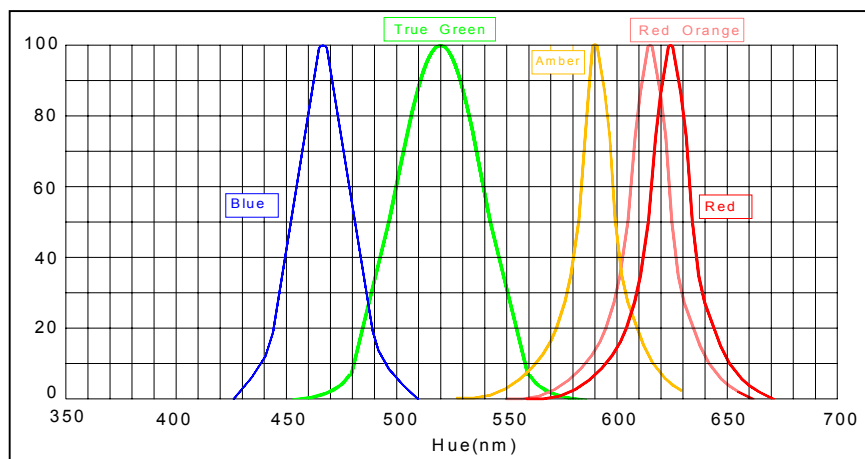
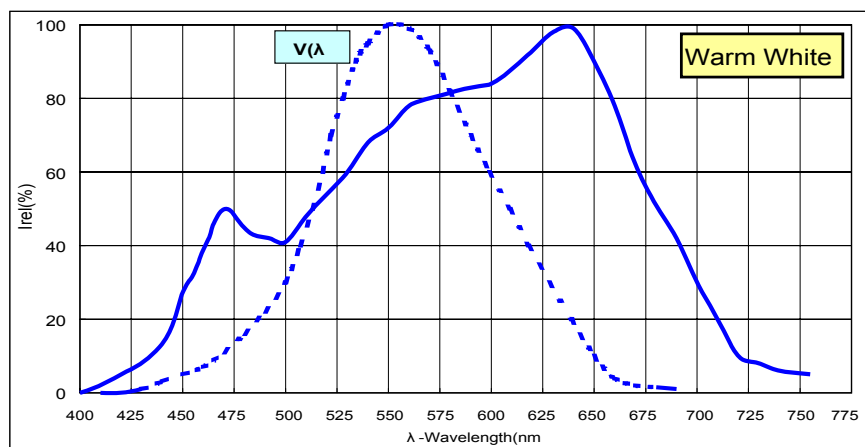
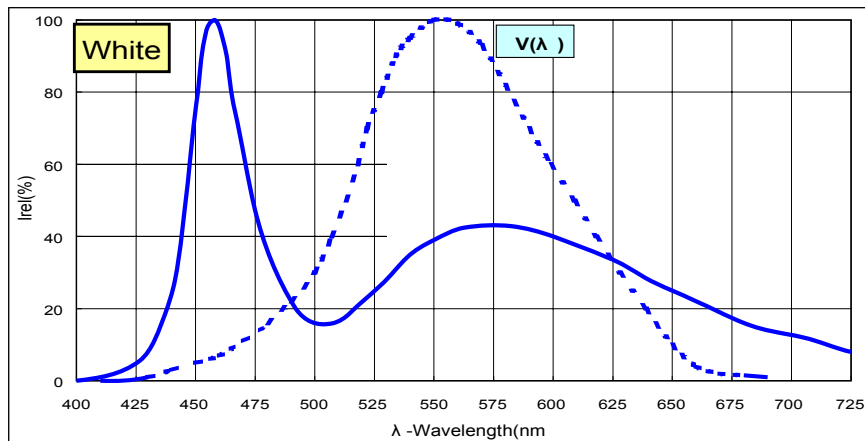

**Typical Radiation Pattern for Lambertian**

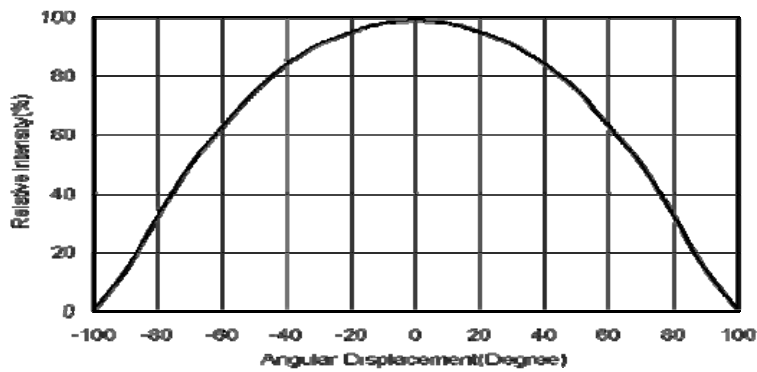

**Typical Optical and Electrical Curves**

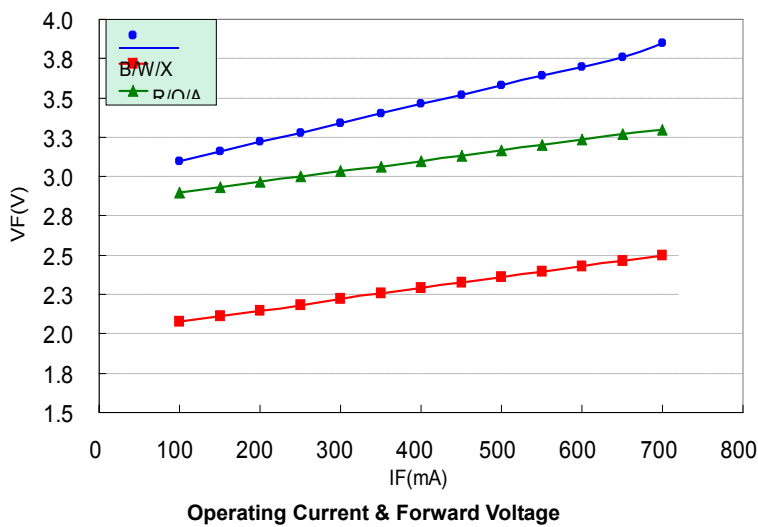
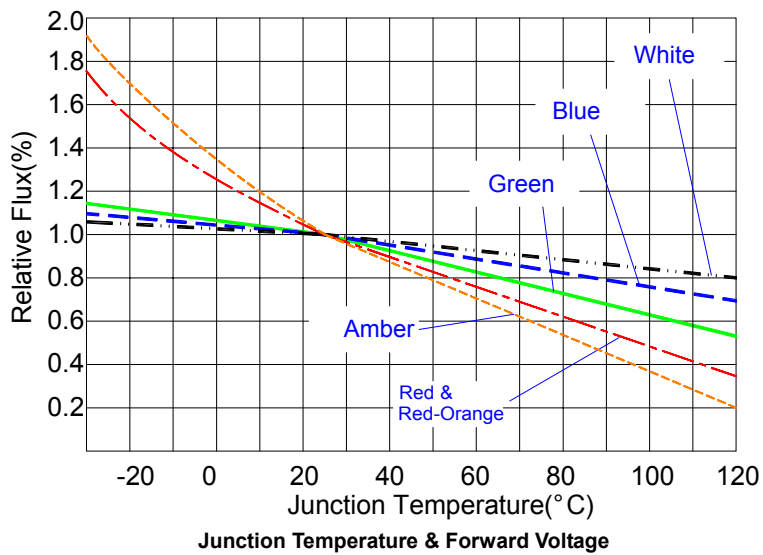

## Typical Optical and Electrical Curves

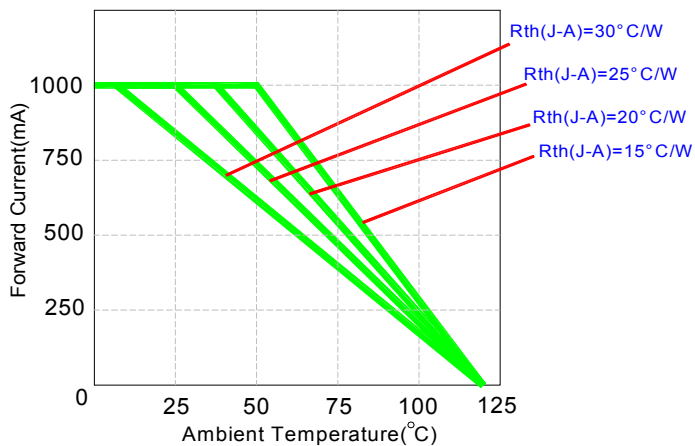

Operating Current & Ambient Temperature

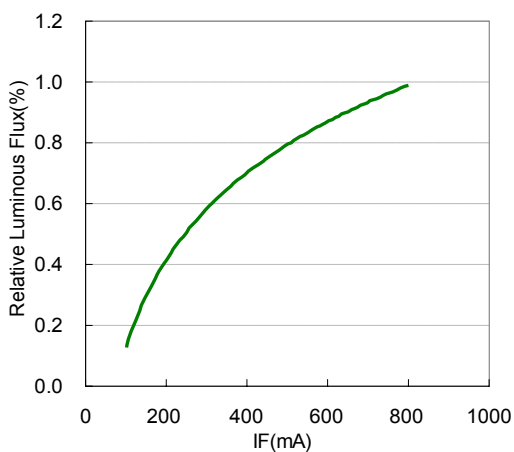

Forward Current & Luminous Flux

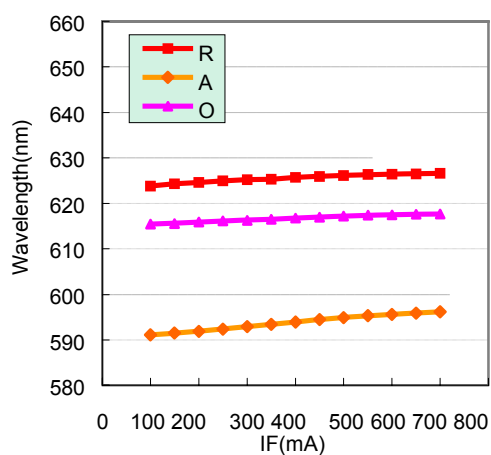
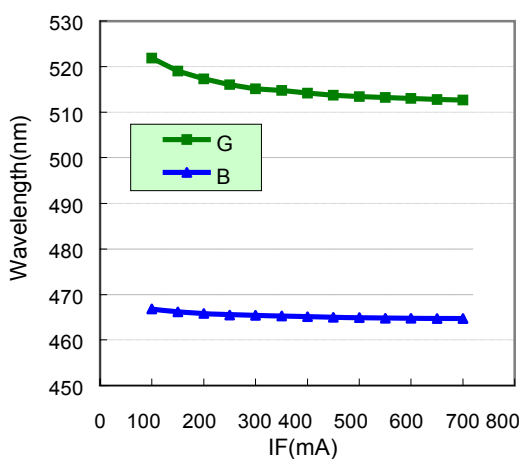

Forward Current & Wavelength

## Package Specifications

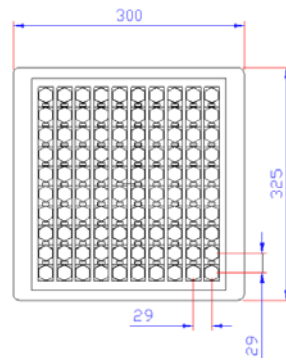
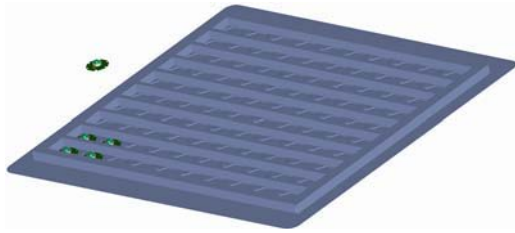

Figure 1: Tray

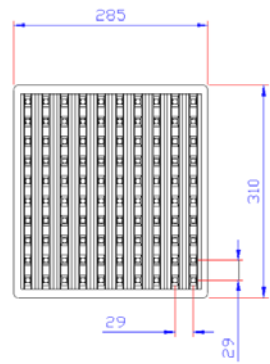

Figure 2: Cover

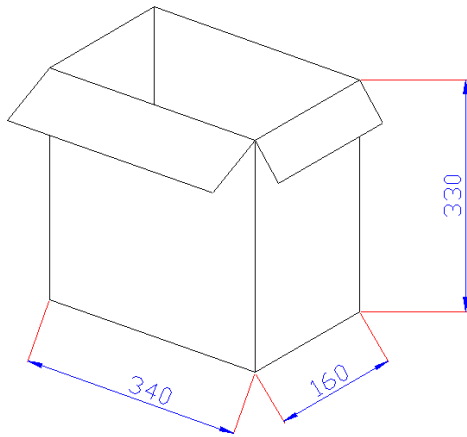

Figure 3: Inner box

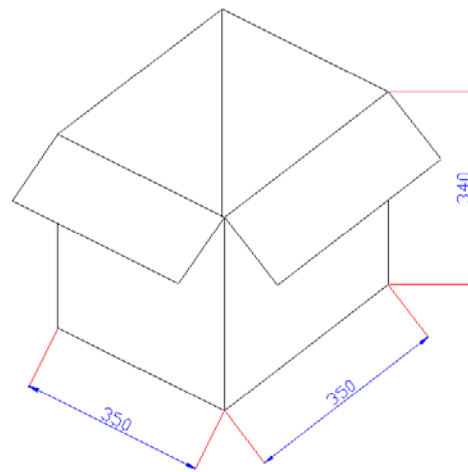

Figure 4: Outer box

### Note

1. All dimensions are in mm.
2. There are 100pcs stars in a tray.(Tray+Cover)
3. There are 10 trays in an inner box.
4. There are 2 inner boxes in an outer box.