



**APEX OPTO
CORP**

**HIGH POWER LIGHT
AOL-EXXXA3
IR Series**



IR Series are one of the highest power LEDs in the world by Apex Opto. IR Series are designed to satisfy more and more Solid-State lighting High Power LED applications for brilliant world such as CCTV.

Features

- Low voltage operated
- Instant light
- Long operating life

Typical Applications

- CCTV
- Wireless communication

Package Outlines

Lambertian

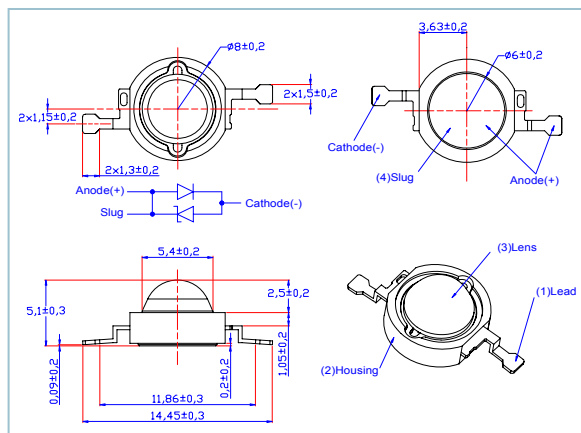

Focusing

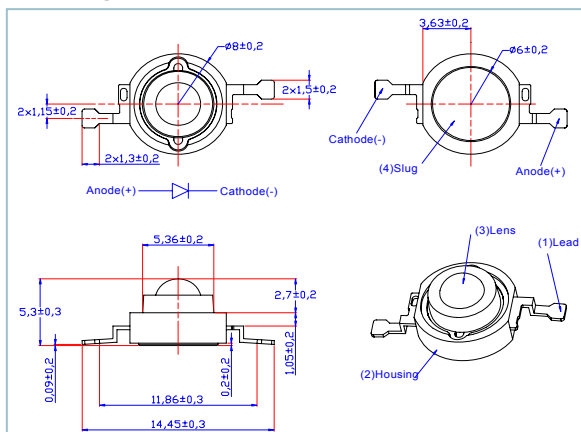

Notes:

1. All dimensions are in mm.
2. Drawings are not to scale.
3. It is strongly recommended that the temperature of lead be not higher than 55°C .
4. Lambertian series slug has polarity as anode.
5. It is important that the slug can't contact aluminum surface, It is strongly recommended that there should coat a uniform electrically isolated heat dissipation film on the aluminum surface.

Absolute Maximum Ratings

Parameter	Symbol	Rating	Units
DC Forward Current	I_F	700	mA
Peak pulse current;(tp ≤ 100μs, Duty cycle=0.25)	I_{pulse}	2000	mA
Reverse Voltage	V_R	5	V
Reverse Current @ $V_R=5V$	I_R	50	μA
LED junction Temperature @ 700 mA	T_j	125	°C
Operating Temperature	T_{opr}	-30 ~ +110	°C
Storage Temperature	T_{stg}	-40 ~ +120	°C
Manual Soldering Time at 260°C(Max.)	T_{sol}	5	seconds

AOL-EI1LA3 Optical & Electrical Characteristics at $I_F=700mA(T_a=25°C, T_{opr}=100ms)$

Parameter	Symbol	Values			Units
		Min.	Typ.	Max.	
Viewing angle at 50% I_v	$2\theta_{1/2}$	--	120	--	deg.
Viewing angle at 50% I_v (with Collimator)	$2\theta_{1/2}$	--	25	--	deg.
Forward voltage	V_F	1.5	1.9	2.4	V
Radiant Power	Power	--	200	--	mW
Radiant Intensity	I_v	--	60	--	mW/Sr
Radiant Intensity (with Collimator)	I_v	--	500	--	mW/Sr
Peak Wavelength	λ_P	--	850	--	nm
Thermal Resistance Junction to Board	$R\theta_{J-C}$	--	15	--	°C/W
Temperature Coefficient Of Forward Voltage	$\Delta V_F/\Delta T$	--	-2	--	mV/°C

AOL-EI1FA3 Optical & Electrical Characteristics at $I_F=700mA(T_a=25°C, T_{opr}=100ms)$

Parameter	Symbol	Value			Units
		Min.	Typ.	Max.	
Viewing angle at 50% I_v	$2\theta_{1/2}$	--	50	--	deg.
Forward voltage	V_F	1.5	1.9	2.4	V
Radiant Power	Power	--	180	--	mW
Radiant Intensity	I_v	--	150	--	mW/Sr
Peak Wavelength	λ_P	--	850	--	nm
Thermal Resistance Junction to Case	$R\theta_{J-C}$	--	15	--	°C/W
Temperature Coefficient Of Forward Voltage	$\Delta V_F/\Delta T$	--	-2	--	mV/°C

AOL-EIALA3 Optical & Electrical Characteristics at $I_F=350\text{mA}$ ($T_a=25^\circ\text{C}$, $T_{\text{onr}}=100\text{ms}$)

Parameter	Symbol	Value			Units
		Min.	Typ.	Max.	
Viewing angle at 50% I_V	$2\theta_{1/2}$	--	120	--	deg.
Forward voltage	V_F	1.2	1.6	2.1	V
Radiant Power	Power	--	100	--	mW
Radiant Intensity	I_V	--	30	--	mW/Sr
Peak Wavelength	λ_P	--	850	--	nm
Thermal Resistance Junction to Case	$R\theta_{J-C}$	--	15	--	$^\circ\text{C}/\text{W}$
Temperature Coefficient Of Forward Voltage	$\Delta V_F/\Delta T$	--	-2	--	mV/ $^\circ\text{C}$

AOL-EN1LA3 Optical & Electrical Characteristics at $I_F=700\text{mA}$ ($T_a=25^\circ\text{C}$, $T_{\text{onr}}=100\text{ms}$)

Parameter	Symbol	Value			Units
		Min.	Typ.	Max.	
Viewing angle at 50% I_V	$2\theta_{1/2}$	--	140	--	deg.
Forward voltage	V_F	1.5	1.9	2.4	V
Radiant Power	Power	--	70	--	mW
Radiant Intensity	I_V	--	35	--	mW/Sr
Peak Wavelength	λ_P	--	940	--	nm
Thermal Resistance Junction to Case	$R\theta_{J-C}$	--	15	--	$^\circ\text{C}/\text{W}$
Temperature Coefficient Of Forward Voltage	$\Delta V_F/\Delta T$	--	-2	--	mV/ $^\circ\text{C}$

Note

1. Radiometric is measured with an accuracy of $\pm 10\%$.
2. Forward Voltage is measured with an accuracy of $\pm 0.1\text{V}$
3. Wavelength is measured with an accuracy of $\pm 2\text{nm}$

Electrical & Optical Curves-Spectrum

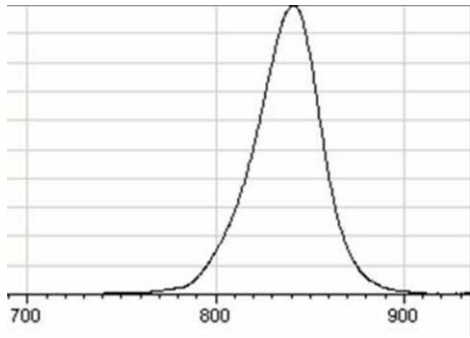

AOL-EIxxA3 spectrum

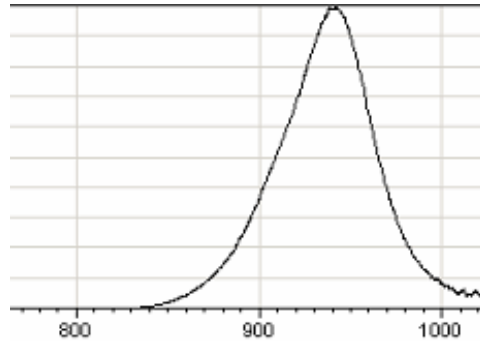

AOL-ENxxA3 spectrum

Typical Radiation Pattern for

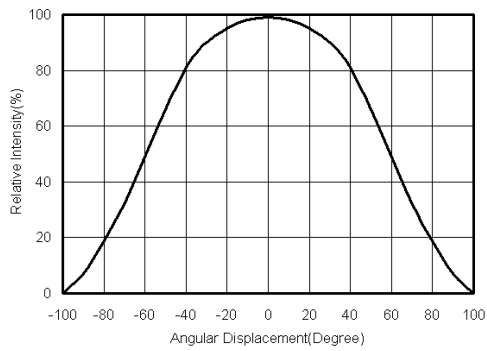

AOL-EI1LA3 & AOL-EIALA3

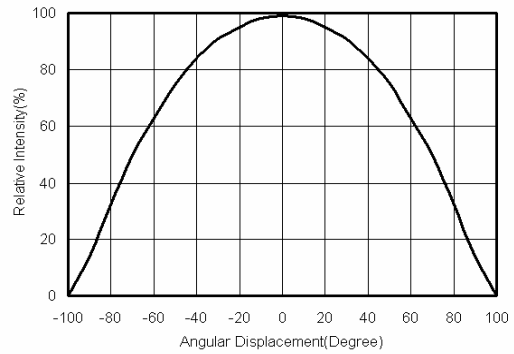

AOL-EN1LA3

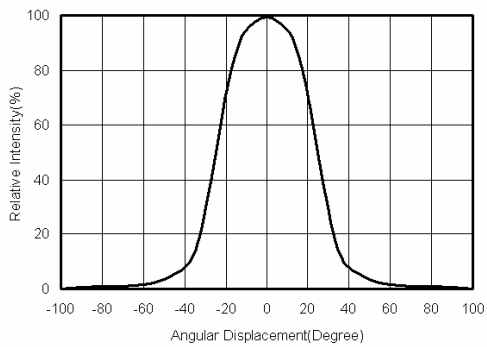

AOL-EI1FA3

Typical Optical and Electrical Curves

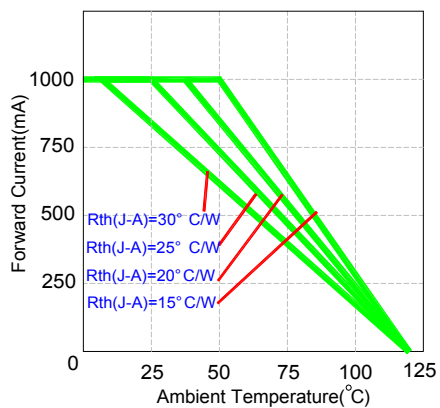

**Operating Current & Ambient Temperature
For AOL-Ex1LA3**

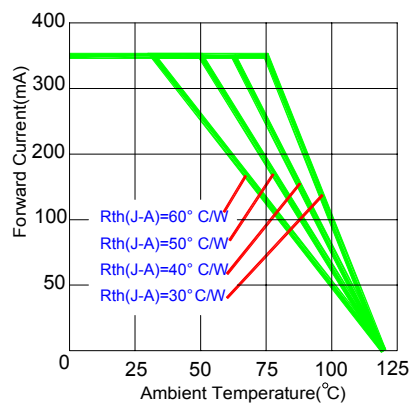

**Operating Current & Ambient Temperature
For AOL-ExALA3**

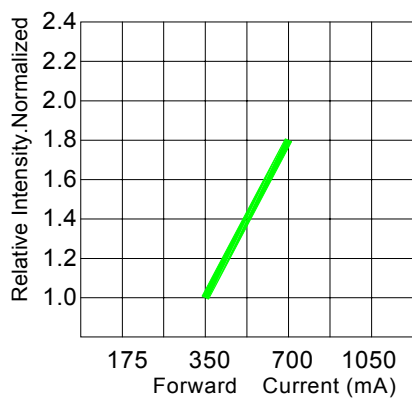

Forward Current & Luminous Flux

Package Specifications

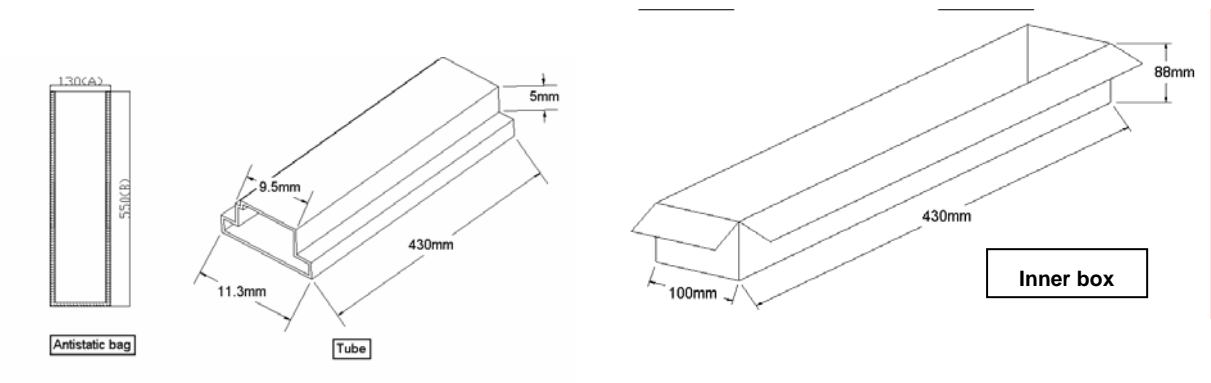

Note

1. All dimensions are in mm.
2. There are 50pcs emitters in a tube
3. There are 20 tubes in a bag
4. There are 2 bags in a inner box
5. A bag contains one humidity indicator card and drying agent