



**APEX OPTO  
CORP**

## **HIGH POWER LIGHT AOL-DCD9-R1**



APEX are designed by particular package for High Power LED.

DCD9 can be driven current from 350mA to 700mA in same package. APEX contains no mercury and has more energy efficient than other incandescent light source.

### **Features**

**More energy efficient than incandescent and most halogen lamps**

**Low voltage operated**

**Instant light**

**Long operating life**

### **Typical Applications**

**Reading lights**

**Portable flashlight**

**Up-lighters and Down-lighters**

**LCD Backlights**

**General lighting**

**Contour lights Ceiling**

**lights Garden lighting**

**Decoration lights**

**Architectural lighting**

**Beacon lights**

## Package Outlines

### Lambertian

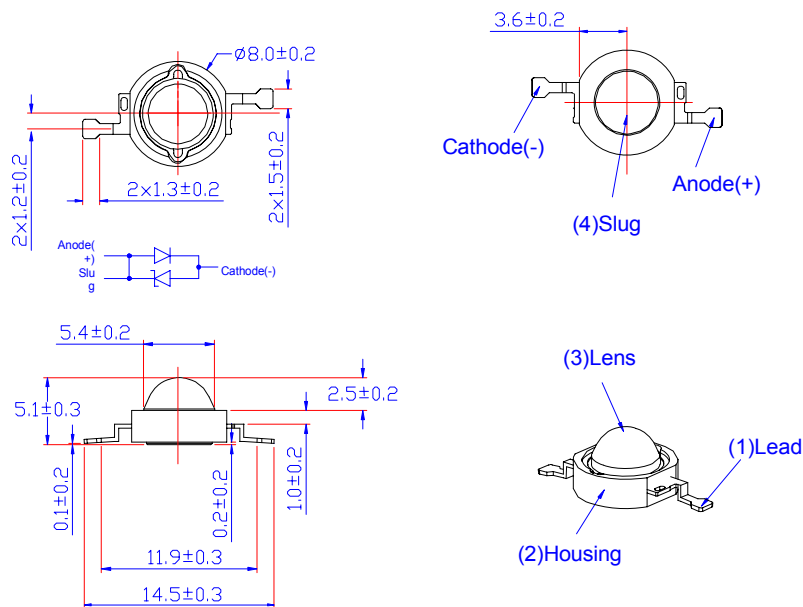

### Notes:

1. All dimensions are in mm.
2. Drawings are not to scale.
3. It is strongly recommended that the temperature of lead be not higher than  $55^{\circ}\text{C}$ .
4. The slug has polarity as anode.
5. It is important that the slug can't contact aluminum surface, It is strongly recommended that there should coat a uniform electrically isolated heat dissipation film on the aluminum surface.

## Absolute Maximum Ratings

Parameter	Symbol	Rating	Units
DC Forward Current	$I_F$	700	mA
Reverse Voltage	$V_R$	5	V
Arc Voltage	$V_{FC}$	16	V
LED junction Temperature	$T_j$	150	°C
Operating Temperature	$T_{opr}$	-30 ~ +110	°C
Storage Temperature	$T_{stg}$	-40 ~ +120	°C
ESD Sensitivity	$V_B$	4,000	V
Manual Soldering Time at 260°C (Max.)	$T_{sol}$	5	seconds

### Notes:

1. Proper current derating must be observed to maintain junction temperature below the maximum.
2. LEDs are not designed to be driven in reserve bias.

### Luminous Flux or Radiometric Power Characteristics at $I_F=350\text{mA}$ and $T_J=25^\circ\text{C}$ :

Lens Item	Part Name	Color	Flux/Power			Units
			Min.	Typ.	Max.	
	AOL-EWDCD9-B1	White	66.5	85.0	--	lm
	AOL-EXDCD9-A1	Warm White	51.2	70.0	--	lm
Lambertian	AOL-EBDCD9-01	Blue	13.8	20.0	--	lm
	AOL-EDDCD9-01	Dental Blue	170.9	280.0	--	mW
	AOL-ECDCD9-01	Royal Blue	170.9	280.0	--	mW

### Luminous Flux or Radiometric Power Characteristics at $I_F=700\text{mA}$ and $T_J=25^\circ\text{C}$ :

Lens Item	Part Name	Color	Flux/Power			Units
			Min.	Typ.	Max.	
	AOL-EWDCD9-B3	White	112.5	160.0	--	lm
	AOL-EXDCD9-A3	Warm White	86.5	130.0	--	lm
Lambertian	AOL-EBDCD9-03	Blue	23.3	36.0	--	lm
	AOL-EDDCD9-03	Dental Blue	384.4	520.0	--	mW
	AOL-ECDCD9-03	Royal Blue	384.4	520.0	--	mW

**Color Temperature or Dominant Wavelength<sup>\*1</sup> or Peak Wavelength<sup>\*2</sup> T<sub>J</sub>=25°C**  
**Characteristics**

Lens Item	Part Name	Color	CCT			Units
			Min.	Typ.	Max.	
Lambertian	AOL-EWDCD9-Bx	White	4,500	--	10,000	K
	AOL-EXDCD9-Ax	Warm White	2,800	--	3,800	K
	AOL-EBDCD9-0x	Blue <sup>*1</sup>	460	--	475	nm
	AOL-EDDCD9-0x	Dental Blue <sup>*2</sup>	450	--	460	nm
	AOL-ECDCD9-0x	Royal Blue <sup>*2</sup>	440	--	450	nm

**Forward Voltage Characteristics at T<sub>J</sub>=25°C:**

Lens Item	Part Name	Forward Current (mA)	V <sub>F</sub>			Units
			Min.	Typ.	Max.	
Lambertian	AOL-ExDCD9-x1	350	2.8	--	3.7	V
	AOL-ExDCD9-x3	700	3.1	--	4.0	

**Emission Angle Characteristics**

Lens Item	Part Name	2Θ <sub>½</sub> (Typ.)	Units
		Lambertian	
Lambertian	AOL-ExDCD9-xx	120	Degrees

**Thermal Resistance Junction to Case Characteristics**

Lens Item	Part Name	R <sub>θJ-B</sub>	Units
		Typ.	
Lambertian	AOL-ExDCD9-xx	12	°C/W

**Luminous Flux or Radiometric Power<sup>\*1</sup> Bin Group:**

Part No.	Test Current(mA)	Group	Min.	Max.
AOL-EWDCD9-B1	350	TD	66.5	86.5
		UD	86.5	112.5
AOL-EWDCD9-B3	700	VD	112.5	146.2
		WD	146.2	190.0
AOL-EXDCD9-A1	350	SD	51.2	66.5
		TD	66.5	86.5
AOL-EXDCD9-A3	700	UD	86.5	112.5
		VD	112.5	146.2
AOL-EBDCD9-01	350	MD	13.8	17.9
		ND	17.9	23.3
AOL-EBDCD9-03	700	PD	23.3	30.3
		QD	30.3	39.4
AOL-EDDCD9-01 <sup>*1</sup>	350	HD	170.9	256.3
		JD	256.3	384.4
AOL-EDDCD9-03 <sup>*1</sup>	700	KD	384.4	576.7
		LD	576.7	865.0
AOL-ECDCD9-01 <sup>*1</sup>	350	HD	170.9	256.3
		JD	256.3	384.4
AOL-ECDCD9-03 <sup>*1</sup>	700	KD	384.4	576.7
		LD	576.7	865.0

**Note**

1. Flux & power is measured with an accuracy of  $\pm 10\%$ .
2. CCT selection acc. to CCT groups and an accuracy of  $\pm 200K$
3. Forward Voltage is measured with an accuracy of  $\pm 0.1V$

**JEDEC Moisture Sensitivity:**

Level	Floor Life		Soak Requirements			
	Time	Conditions	Standard Time (hours)	Standard Conditions	Accelerated Environment Time (hours)	Accelerated Environment Conditions
2a	4 weeks	≤30°C / 60% RH	696 +5/-0	30°C / 60% RH	120 +1/-0	60°C / 60% RH

LEVEL	FLOOR LIFE		SOAK REQUIREMENTS			
			STANDARD		ACCELERATED EQUIVALENT <sup>1</sup>	
	TIME	CONDITIONS	TIME (hours)	CONDITIONS	TIME (hours)	CONDITIONS
1	Unlimited	≤30°C/85% RH	188 +5/-0	85°C/85% RH		
2	1 year	≤30°C/80% RH	188 +5/-0	85°C/80% RH		
2a	4 weeks	≤30°C/80% RH	696 <sup>2</sup> +5/-0	30°C/80% RH	120 +1/-0	60°C/80% RH
3	188 hours	≤30°C/80% RH	192 <sup>2</sup> +5/-0	30°C/80% RH	40 +1/-0	60°C/80% RH
4	72 hours	≤30°C/80% RH	96 <sup>2</sup> +2/-0	30°C/80% RH	20 +0.5/-0	60°C/80% RH
5	48 hours	≤30°C/80% RH	72 <sup>2</sup> +2/-0	30°C/80% RH	15 +0.5/-0	60°C/80% RH
5a	24 hours	≤30°C/80% RH	48 <sup>2</sup> +2/-0	30°C/80% RH	10 +0.5/-0	60°C/80% RH
6	Time on Label (TOL)	≤30°C/80% RH	TOL	30°C/80% RH		

**Note**

1. The standard soak time includes a default value of 24 hours for semiconductor manufacturer's exposure time (MET) between bake and bag and includes the maximum time allowed out of the bag at the distributor's facility.

**Operating life, mechanical, and environmental tests performed on apex package:**

Stress Test	Stress Conditions	Stress Duration	Failure Criteria
Room Temperature Operating Life	25°C, I <sub>F</sub> = max DC (Note 1)	1000 hours	Note 2
High Temperature High Humidity	85°C / 85%RH	1000 hours	Note 2
Temperature Cycle	-40°C/100°C ,30 min dwell / <5min transfer	200 cycles	Note 2
High Temperature Storage Life	110°C	1000 hours	Note 2
Low Temperature Storage Life	-55°C	1000 hours	Note 2
Thermal Shock	-40 / 120°C, 20 min dwell / <20 sec transfer	200 cycles	No catastrophics
Mechanical Shock	1500 G, 0.5 msec pulse, 5 shocks each 6 axis		No catastrophics
Natural Drop	On concrete from 1.2 m, 3X		No catastrophics
Variable Vibration Frequency	10-2000-10 Hz, log or linear sweep rate, 20 G about 1 min, 1.5 mm, 3X/axis		No catastrophics
Solder Heat Resistance (SHR)	260°C ± 5°C, 10 sec		No catastrophics
Solderability	Steam age for 16 hr, then solder dip at 260°C for 5 sec		Solder coverag on lead

**Note**

1. Depending on the maximum derating curve.

2. Failure Criteria:

Electrical failures

V<sub>F</sub> shift >=10%

I<sub>R</sub><50uA @V<sub>r</sub>=5V

Light Output Degradation

% I<sub>v</sub> shift >= 30% @1,000hrs or 200cycle

Visual failures

Broken or damaged package or lead

Solderability < 95% wetting

Dimension out of tolerance

## Burn-in Condition APEX Reliability

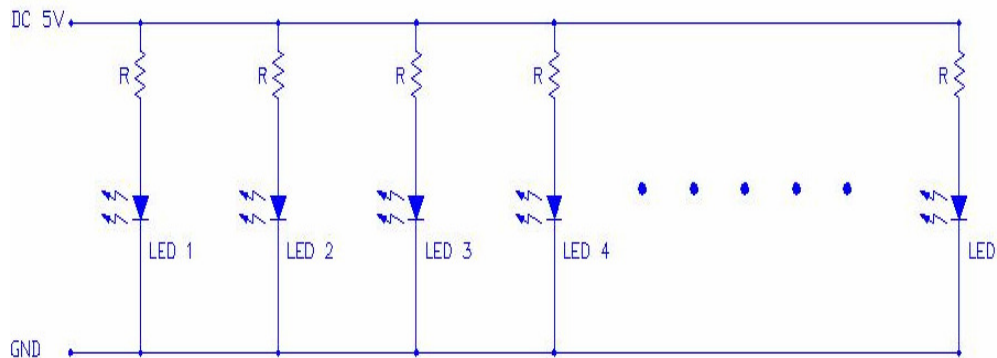

When we talk about MTBF of APEX, we can provide a formula for customers.

$$\log(\text{Life}) = \frac{1,600}{T_j(^{\circ}\text{C}) + 273}$$

Life means the time light output becomes 70%

T <sub>j</sub> (°C)	Life (hours)	T <sub>j</sub> (°C)	Life (hours)
25	234,000	85	29,500
30	191,000	90	25,700
35	157,000	95	22,300
40	129,000	100	19,500
45	107,000	105	17,100
50	90,000	110	15,100
55	75,000	115	13,300
60	64,000	120	11,700
65	54,000	125	10,500
70	46,000	130	9,300
75	39,600	140	7,500
80	34,000	150	6,000

When we talk about MTBF of APEX, we can provide a formula for MTBF is assumed to be 100,000,000

The failure rates at different hours and different systems(LED quantity) are as below:

if there is 1 failure of 1 emitter in a system

Tj=75°C is giving 0.01%(100ppm) at 10,000hrs

if there is 1 failure of 10 emitters in a system

Tj=75°C is giving 0.1%(1,000ppm) at 10,000hrs

if there is 1 failure of 1 emitter in a system

Tj=75°C is giving 0.05%(500ppm) at 50,000hrs

if there is 1 failure of 10 emitters in a system

Tj=75°C is giving 0.5%(5,000ppm) at 50,000hrs if there are 10 emitters

### How to Know Tj in Your Application?

If it is white APEX, Rth(junction to case)=15°C/W

The thermal grease is 200um.

K(Aluminum PCB)=2.6 W/mk

$$\text{Then Rth(case to board)} = \frac{200}{2.6 \times (6.4/2)^2 \pi} = 2.4 \text{ } ^\circ\text{C/W}$$

The Rth between board and air is mainly dependent on the total surface air.

$$\text{Rth(board-air)} = \frac{500}{\text{Area(cm}^2\text{)}}$$

If Area is 30cm<sup>2</sup> Rth=16.7 T (junction-air)=(15+2.4+16.7)x1=34.1 °C

If Area is 60cm<sup>2</sup> Rth=8.3 T(junction-air)=(15+2.4+8.3)x1=25.7 °C

If Area is 90cm<sup>2</sup> Rth=5.5 T (junction-air)=(15+2.4+5.5)x1=22.9 °C

### ASSIST FORM about High Power LED Reliability(Ex: @350mA)

	<u>Ts=45°C</u>	<u>Ts=65°C</u>	<u>Ts=85°C</u>
<b>Voltage</b>	3.3V	3.3V	3.3V
<b>Current</b>	350mA	350mA	350mA
<b>Wattage</b>	1.15W	1.15W	1.15W
<b>Heat</b>	0.96W	0.96W	0.96W
<b>Rth</b>	15 °C/W	15 °C/W	15 °C/W
<b>Tj</b>	59 °C	80.6 °C	99.4 °C
<b>L<sub>70%</sub></b>	64,000hrs	34,000hrs	19,500hrs

## Electrical & Optical Curves-Spectrum

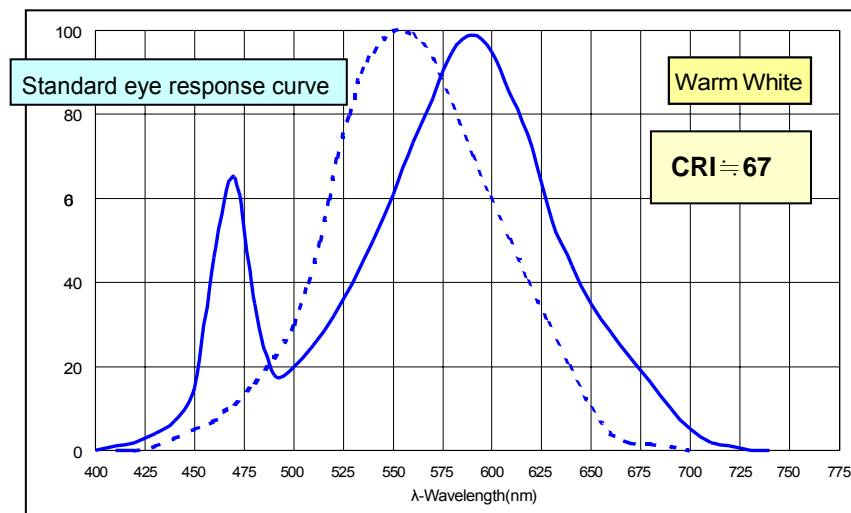
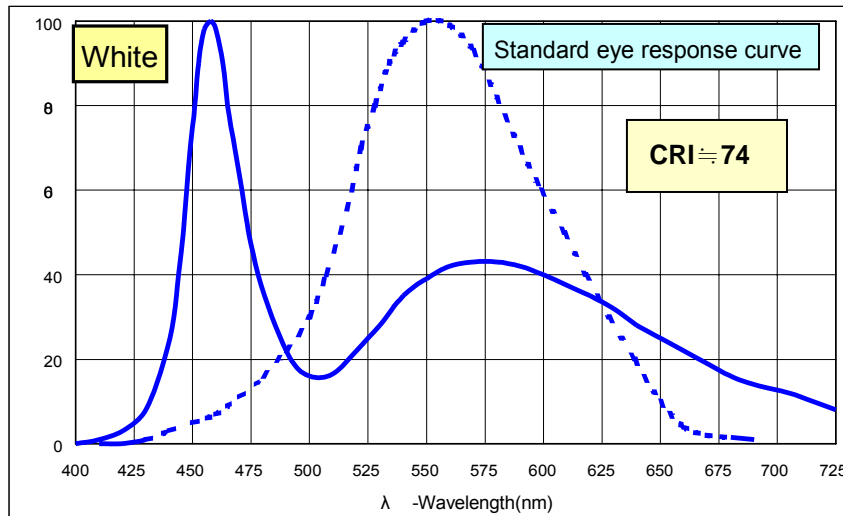

## Typical Radiation Pattern

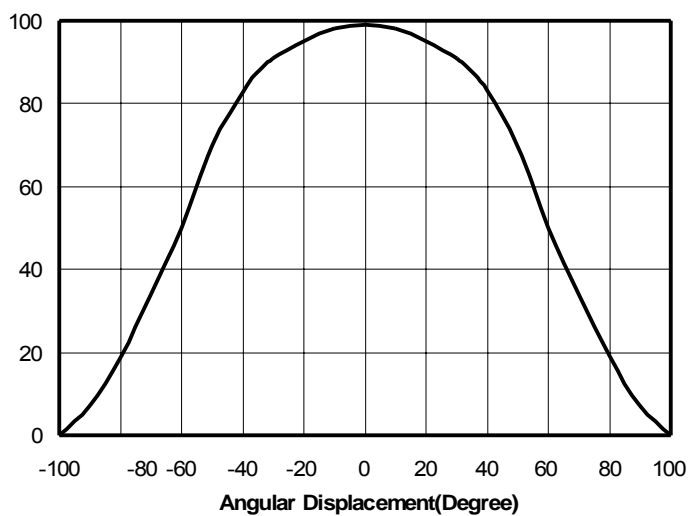

## Typical Optical and Electrical Curves

### Operating Current & Ambient Temperature

#### Current derating curve for 350mA

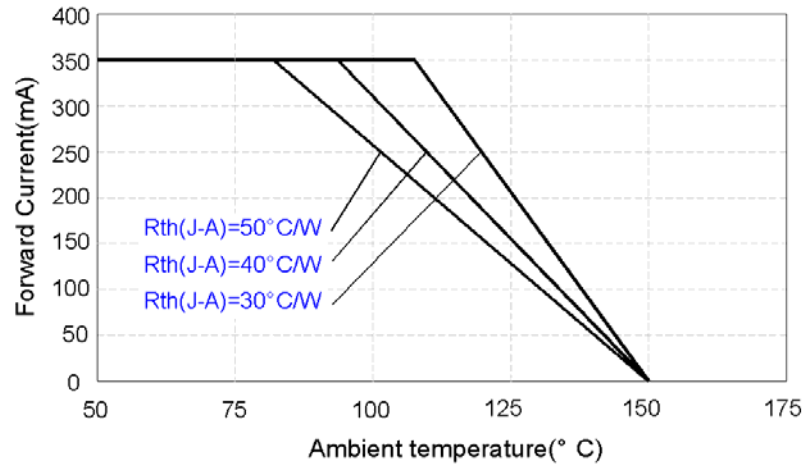

#### Current derating curve for 700mA

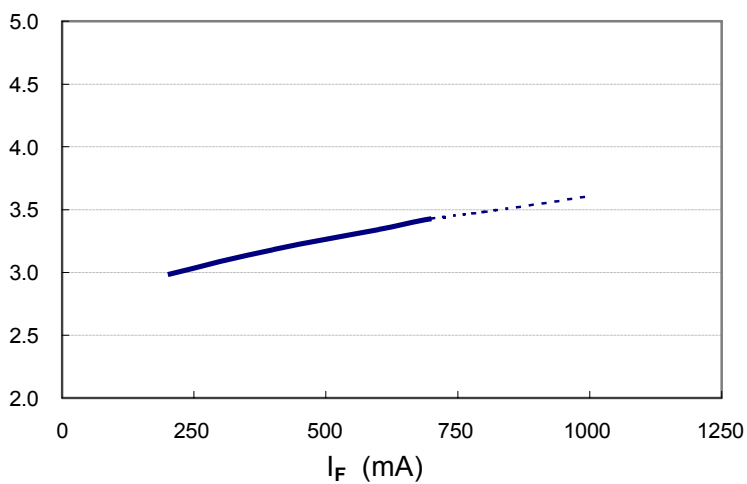
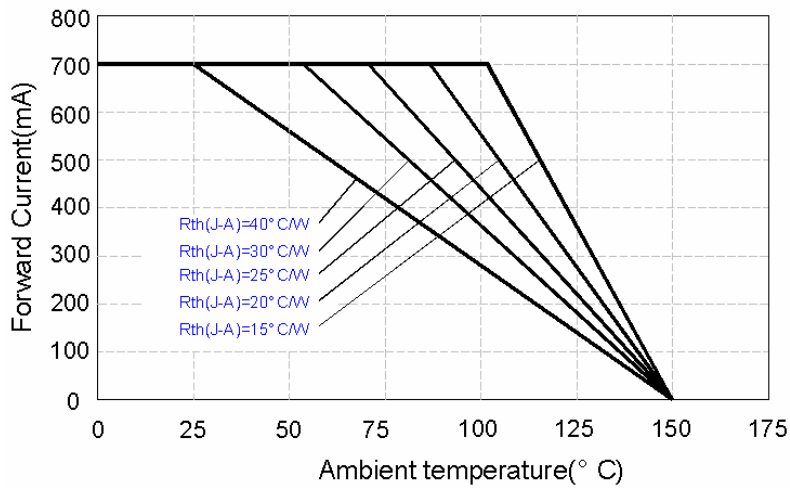

### Operating Current & Forward Voltage

**Typical Optical and Electrical Curves**

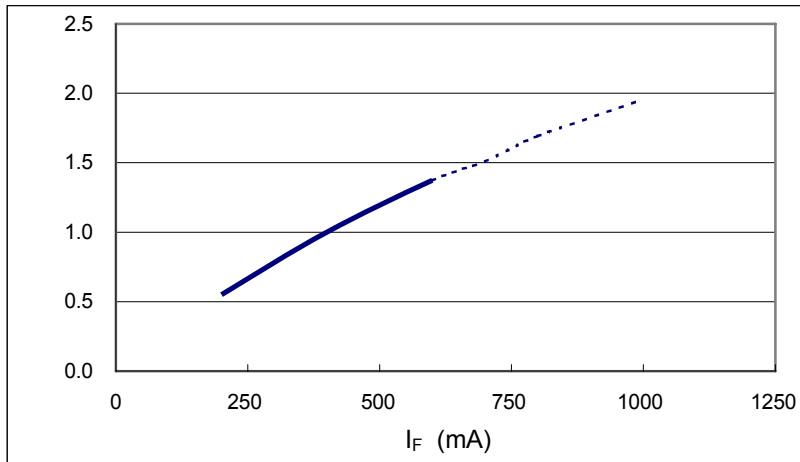

**Forward Current & Luminous Flux**

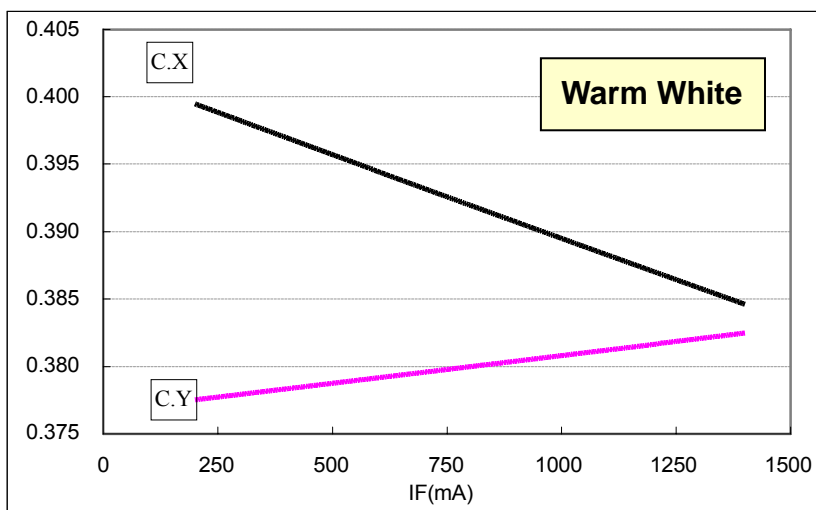
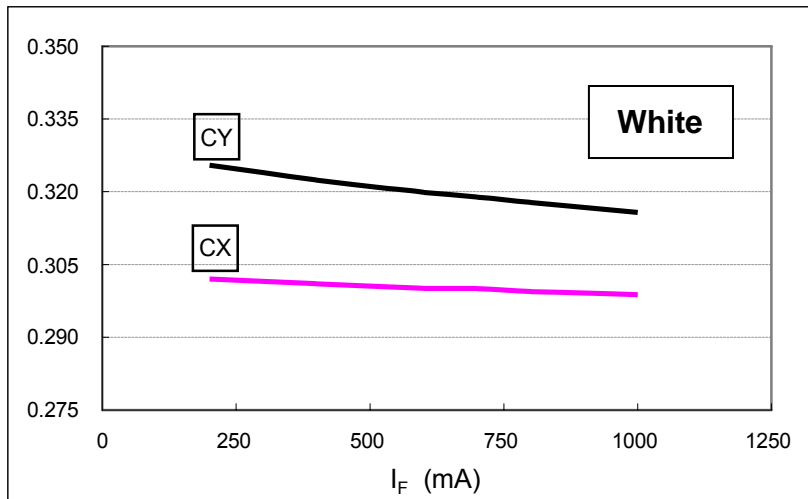

**Forward Current & chromaticity coordinate**

## Recommended Profile for Reflow Soldering

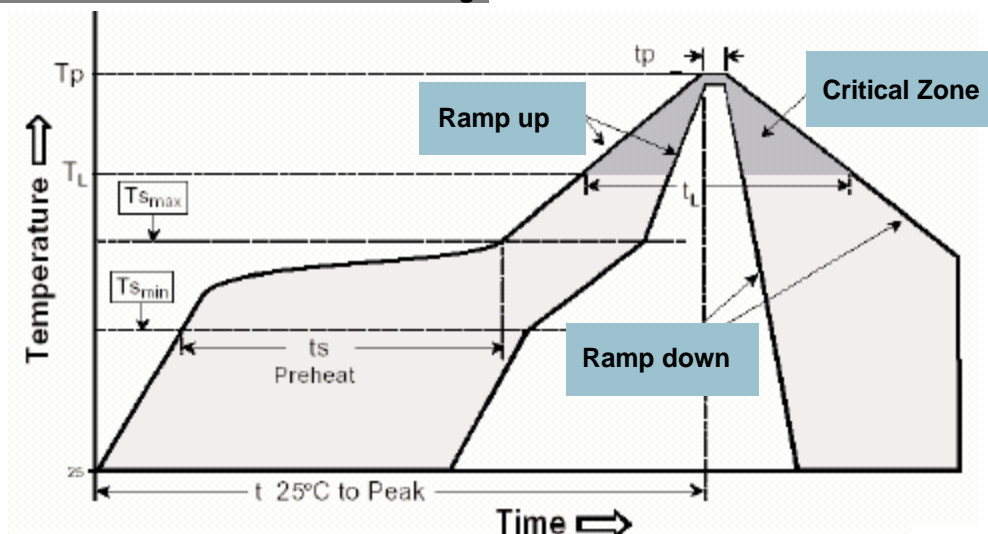

Table 5-2 Classification Reflow Profiles

Profile Feature	Sn-Pb Eutectic Assembly		Pb-Free Assembly	
	Large Body	Small Body	Large Body	Small Body
Average ramp-up rate (T <sub>L</sub> to T <sub>p</sub> )	3°C/second max.		3°C/second max.	
Preheat - Temperature Min (T <sub>min</sub> ) - Temperature Max (T <sub>max</sub> ) - Time (min to max) (t <sub>s</sub> )	100°C 150°C 60-120 seconds		150°C 200°C 60-180 seconds	
T <sub>max</sub> to T <sub>L</sub> - Ramp-up Rate			3°C/second max	
Time maintained above: - Temperature (T <sub>L</sub> ) - Time (t <sub>L</sub> )	183°C 60-150 seconds		217°C 60-150 seconds	
Peak Temperature (T <sub>p</sub> )	225 +0/-5°C	240 +0/-5°C	245 +0/-5°C	250 +0/-5°C
Time within 5°C of actual Peak Temperature (t <sub>p</sub> )	10-30 seconds	10-30 seconds	10-30 seconds	20-40 seconds
Ramp-down Rate	6°C/second max.		6°C/second max.	
Time 25°C to Peak Temperature	6 minutes max.		8 minutes max.	

Note: All temperatures refer to topside of the package, measured on the package body surface.

## Adhesive for Emitter to Aluminum PCB

### Suggestion:

- **Ease of use**  
Non-solvent, One-part
- **Fast tack free**  
3 minutes at 25°C
- **No corrosion**  
Alcohol type of RTV
- **Low volatility**  
Low weight loss of silicone volatiles
- **Adhesion**  
Excellent adhesion to most materials without use of a primer
- **Dielectric properties**  
Cured rubber exhibits good dielectric properties
- **Excellent thermal stability and cold resistance**  
Cured rubber provides wide service temperature range

### Typical Properties

---

<b>Specification</b>	<b>Suggested Properties</b>
Take-free time	3~10 minutes
Specific gravity	< 3 g/cm <sup>2</sup>
Thermal conductivity	> 2.5 W/mK
Rth in using	< 1.8 °C/W
Volume resistance	> 1x10 <sup>14</sup>
Lap shear adhesion strength	> 200 N/ cm <sup>2</sup>
Tensile strength	> 4 Mpa

---

## Package Specifications

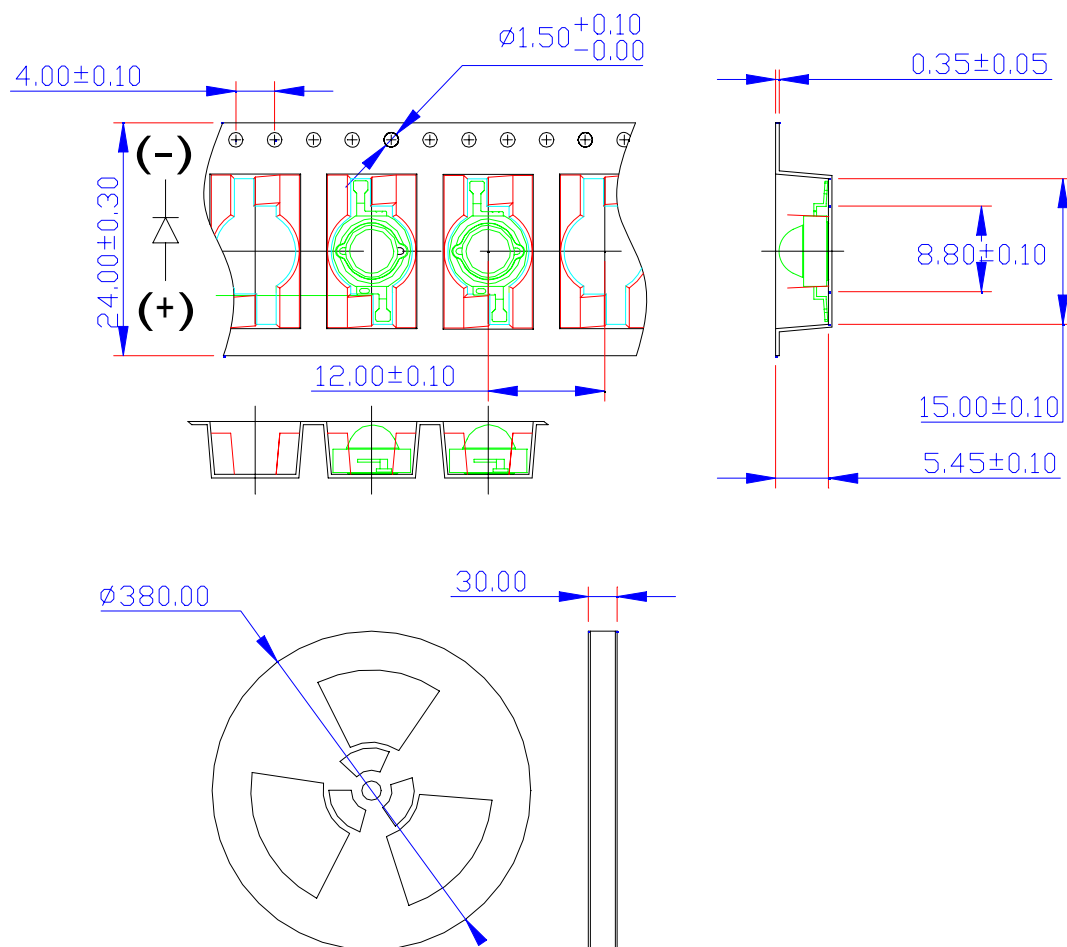

### Notes:

1. All dimensions are in mm.
2. There are 1000pcs emitters in full reel
3. There is a reel in a bag
4. There are 2 bags in an inner box
5. There are 5 inner boxes in an outer box
6. A bag contains one humidity indicator card and drying agent

Packing Step	Type	Dimension(mm)	Emitter Q'ty(Max.)
1	Reel	$\phi 380 * 30.00$	1,000
2	Inner Box	$400 * 385 * 56$	2,000
3	Outer Box	$425 * 405 * 320$	10,000